



# MAGNOLIA

CREATIVE BRIEF



# INTRODUCTION

The series production of the most elegant of all American motorcycle design languages was abandoned in 1942, as the last Indian 4 left the assembly line and World War II began. The designer most associated with the American inline 4, William Henderson, became a historical footnote and for the next eighty-one years, his orphaned motorcycles relied entirely upon the quality of their construction and design to validate his legacy. In all the years since 1942, there has been no corporate interest in his work. The abandonment of progressive American motorcycle design in the category meant the loss of dominance as the producer of the best luxury motorcycles in the world, and the inline 4-cylinder format faded into legend. This is perhaps due to an aversion to risk-taking, but perhaps more accurately represents a poverty of the imagination.



The last American 4-cylinder, the 1942 Indian 4

With humility and reverence, a careful analysis of Henderson's motorcycles provides us with guidance to his construction methodology, design, engineering, proportion, and insight into his very personal quest for the ultimate American high performance luxury motorcycle. His desired outcomes from the first quarter of the 20th Century align with ours in the first quarter of the 21st – Smoothness, power, longevity, and beauty. These benchmarks represent the fulfillment of the promise of the great American touring experience.

Rather than being merely a pastiche of clumsily applied vintage motorcycling styling cues, this new motorcycle will be culturally and contextually relevant. Design from first principles requires understanding of what the giants of the Golden Age of motorcycle design got right, what they got wrong, and what they did not yet know. To this end, an appreciation and sensitivity to the past, without a prostration to it, carries a responsibility to innovate.

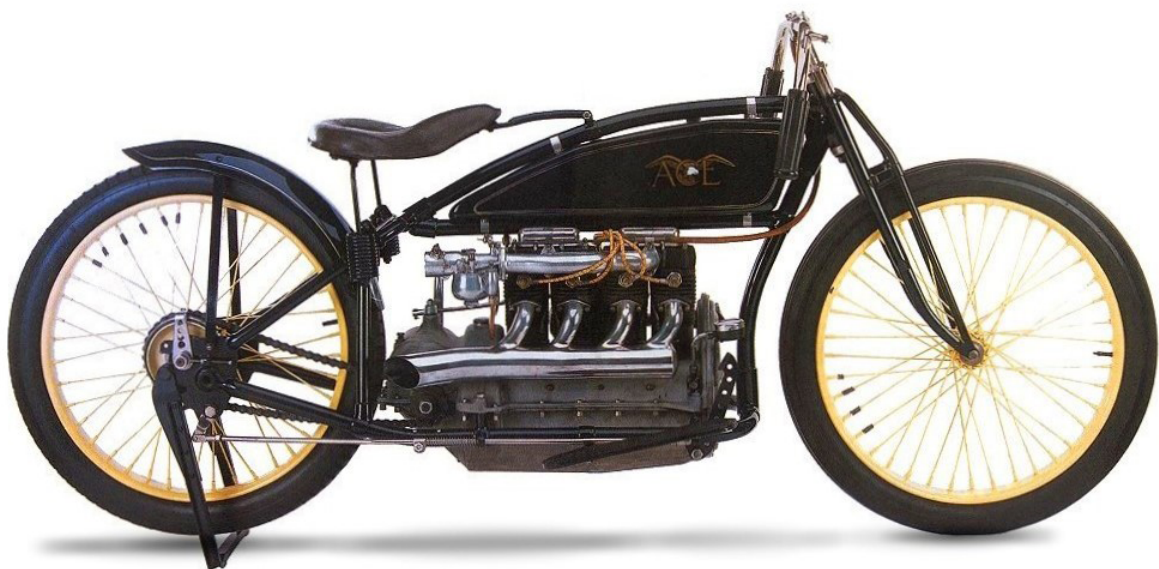

William Henderson's masterpiece, the 1923 Ace XP4

## **This commission will focus on 7 areas of exploration:**

1. Simple but modern engine design breathing new life into the traditional air-cooled American inline 4.
2. Revisiting power transmission considering new EV user interface expectations for ease of use.
3. Suspension adopting a multi-link front fork coupled with hydro pneumatic cylinders and modern geometries.
4. Modern materials and computing power that reinvigorate archaic fabrication methods.
5. Ergonomics that reconciles the man/motorcycle assembly as a whole.
6. The “Century” concept.
7. Visual Identity

The format for communicating these ideas will be a concept vehicle. Concepts should live on the edge of possibility – a delicate balance of reach and grasp. Concepts excite and challenge preconceived notions. Concept vehicles, unlike customized vehicles, serve a higher purpose... we don't build them, they build us, and all great concept vehicles share one thing in common- they are the beginning of something not the end.

# CHAPTER 1

## Engine

Our engine is conservative design, focused on simplicity and durability with the fewest number of moving parts possible. In addition to William Henderson's work, the Bugatti Type 35, Pratt and Whitney Wasp, Rolls Royce Merlin, and Hispano-Suiza V8, are hugely influential for our "First Principles" approach to design.

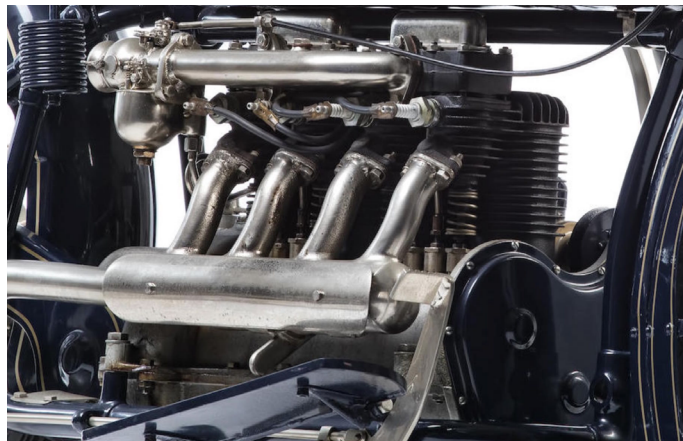

Henderson Ace 4-cylinder

Using Henderson's original bore and stroke dimensions of 2.70 X 3.20 yield a displacement of just over 73 cubic inches and a bore/stroke ratio of .84:1. In addition to the benefits of shortening the engine fore and aft, Under-square geometries provide better rod ratio and piston stability in the bore. Our 3.125 x 3.50 bore and stroke yield a displacement of 107 cubic inches and with a 6.25 inch connecting rod, a rod ratio of 1.79. The bore/stroke ratio of our engine is therefore .9:1, a slightly more modern interpretation of a low-revving torque-oriented engine.

The new philosophy of 4-cylinder cross-plane crankshaft design developed for Moto GP is a good fit for our requirements of high torque at lower RPM over the more conventional flat-plane design that is more suited for developing horsepower at higher RPM. However, the ubiquitous flat plane design has advantages in balancing and manufacturability.

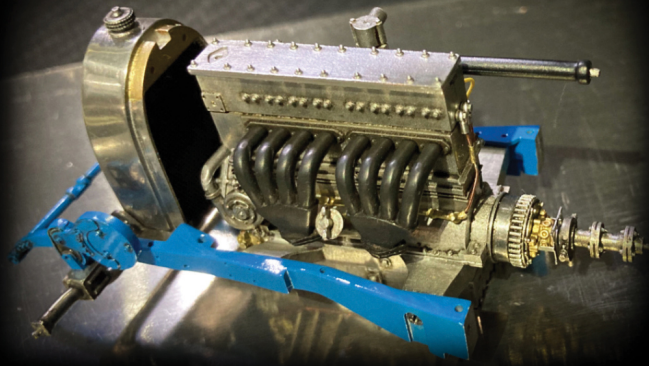

1. Bugatti Type 35 Engine



2. Pratt Whitney Double Wasp Engine

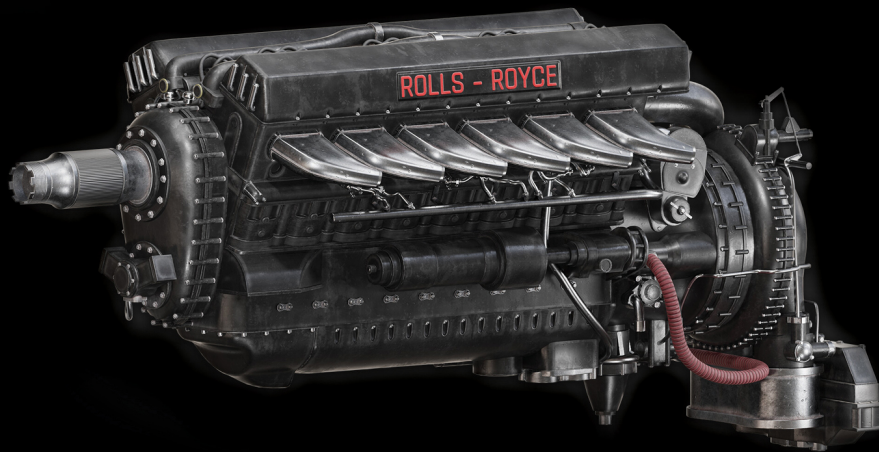

3. Rolls Royce Merlin Engine



4. Hispano Suiza V8 Engine

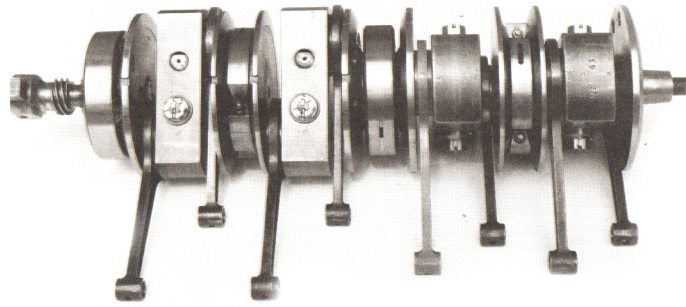

Bugatti Type 35 Crankshaft

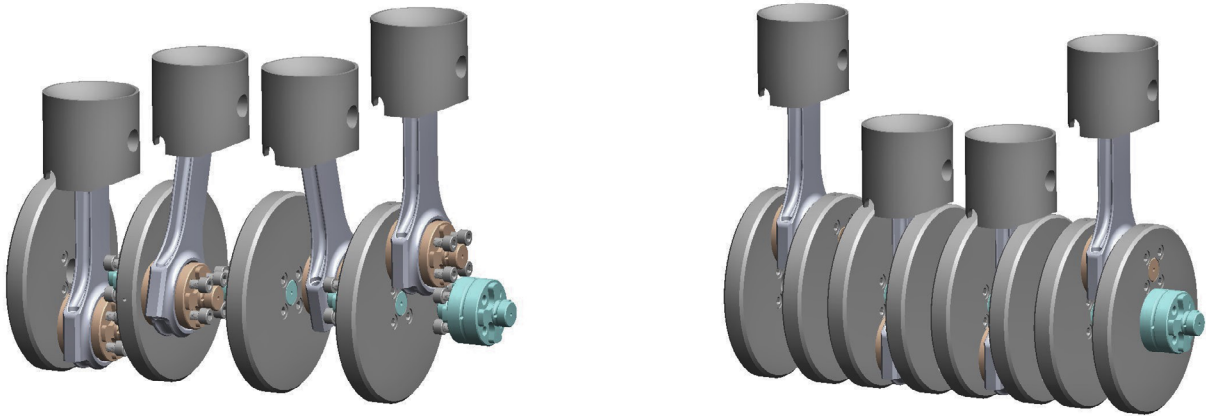

Configurable Crankshaft

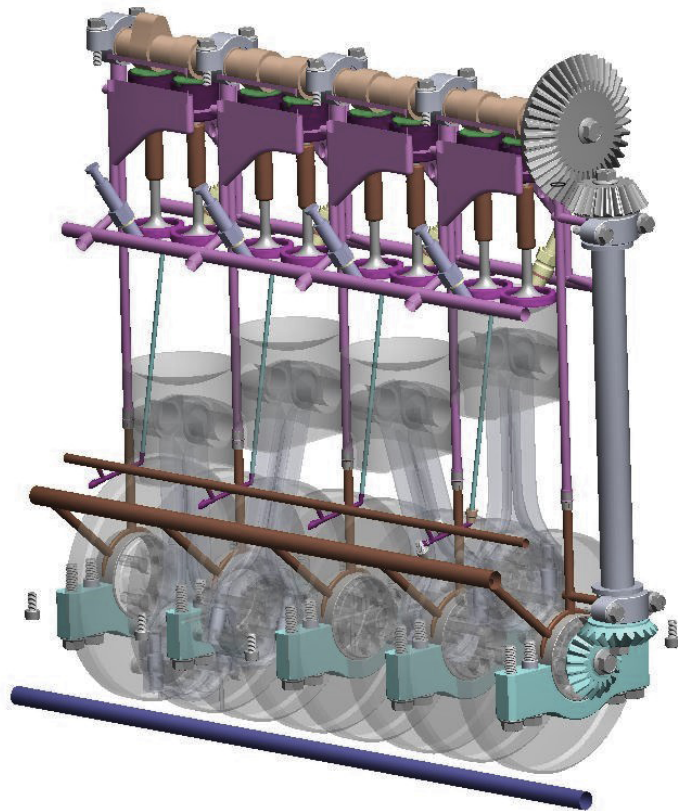

Oiling System



Like the Bugatti Type 35, we are constructing a “built-up” multiple-part crankshaft with one added feature, ours is a fully adjustable crankshaft. This configurable design is built from 3 individual components (rod journal, main journal, and flywheel) that share a common machined locking feature that allows for a range of configurations for testing and production of engines with very different performance characteristics. While engine balancing presents a challenge, the novel transmission design with two contra-rotating, high mass flywheels located at the rear of the engine and geared to the crankshaft provide unique balancing opportunities previously unavailable for conventional motorcycle design. This method of balancing reduces rotational mass along the fore and aft axis of the engine, thereby reducing P-factor and side-to-side rocking.

On the critical topic of engine cooling, in addition to external fins, Henderson cleverly relied on oil slinger cups at the base of the connecting rods to splash-cool the underside of the pistons rendering his engines technically air/oil cooled. Developed by Pratt and Whitney for the Wasp series of air-cooled radial engines, pressurized under piston oil jets were directed at heat extracting fins on the underside of the pistons. This system provides more consistent oil delivery than splash, and efficiently draws heat away from the combustion chamber. Our under-piston oilers have the added benefit of the ability to control the amount of oil delivered (and corresponding cooling vs. metered oil volume) to each individual piston with separate interchangeable oil jets. With varying orifices available, the individual oil jets are threaded into the housing of the under-piston oilers. The entire under-piston oil cooling system pressure is also controlled by a simple rider-controlled valve to aid in engine warm-up, and assist in cooling for higher ambient heat conditions.

In the cylinder head of our engine, a series of 4 oil jets (identical to the under-piston jets) are used to control oil flow to the camshaft and valves. Oil restrictors of various Internal diameters are placed in the external oil drains from the head. This system of oil control to-and-from the head allows the ability to modulate the oil level in the individual oil chambers on either side of the head. Giving the oil appropriate “dwell time” in the head allows for maximum heat absorption and transfer to the separate oil reservoir.

Cooling efficiency via external fins is an expected feature, but often overlooked internal structures are equally important. The difficult process of integrating internal engine cooling fins and crankshaft oil scrapers are only possible with the advent of modern 5-axis machining and extrusion techniques. The goal is a self-cooling engine block, sump, cylinder, and head with no auxiliary cooling systems that is also extremely resistant to thermal expansion.

For fueling, a simple port fuel injection system with a common plenum will satisfy the relatively low volume requirements of our long stroke engine, while upping the intake airspeed to enhance smoothness of throttle. A 2 valve cylinder head satisfies breathing requirements for the correspondingly lowered rev range and eliminate complication. To compensate for the associated loss of RPM-based power, our modern engine will take advantage of the stability of modern fuels with correspondingly modern compression ratios, efficient combustion chamber design, and employ a single, high lift short duration cam.

Like the Rolls Royce Merlin aircraft engine, camshaft drive via bevel gears and drive shaft comes at the cost of efficiency versus a belt or chain drive system, but presents the advantages of longevity and total lack of service requirements. The single overhead cam configuration is simple and robust with the fewest number of moving parts for ease of valve adjustment, and narrowest profile head design.

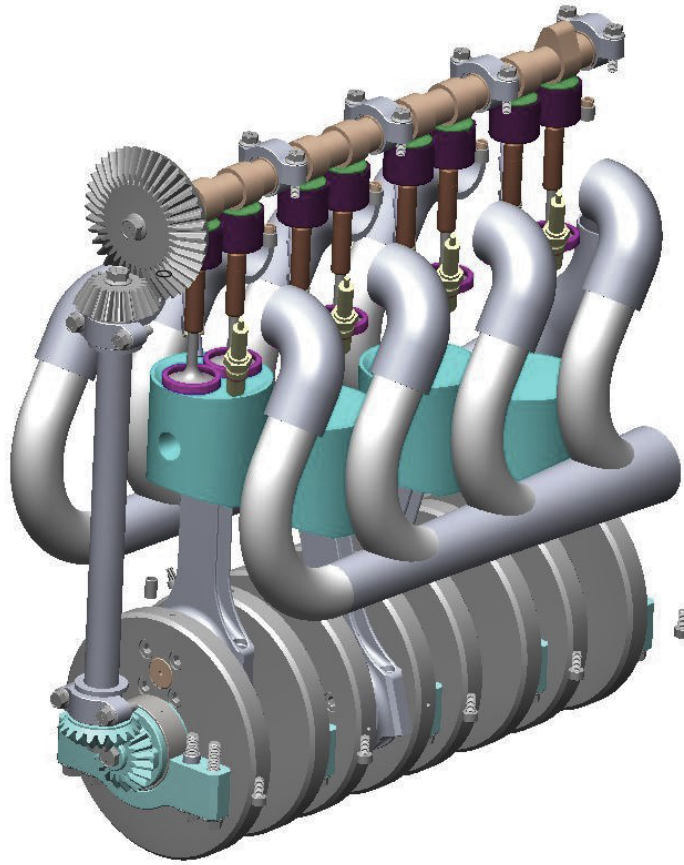

Camshaft Valve Configuration

Shaft and bevel gear drive to a single camshaft is also reminiscent of the work of Marc Birkigt on the magnificent Hispano-Suiza V8. Alignment of the conventional intake and exhaust valves vertically and in the fore to aft axis of the Hispano-Suiza engine, does away with the need for a separate cylinder head. The valve seats can be cut from the bottom of the block as the combustion surface is flat. The combustion chamber is therefore non-hemispherical and now machined into the top of the piston as is utilized in Heron Head designs. This allows the cylinder and head to be unified. The result is a complex single part, but the design eliminates the need for cylinder head gasket, cylinder head studs, stud nuts, and any potential for failure at the joining surface. This system makes servicing the valves more involved than with a separate head design, but with the advantages of fewer parts and the ability to use the cylinder/head assembly as a structural component. This two-valve arrangement fore to aft does not require rocker arms. The single camshaft operates directly above the valve stems in a shim over bucket configuration for ease of adjustment.

The vertical valve arrangement in our non-hemispherical combustion chamber limits the size of the valve head, reducing flow, and must be compensated for with lift and duration on the cam profiles. The deletion of rocker arms, rocker arm shafts, and adjusters allows room for optimized intake and exhaust ports with the absolute fewest number of components.

Through thoughtful thermal management, and structural reinforcement, our engine will also serve as the platform for chassis and suspension components. A true, integrated monolithic structure being a load path providing rigidity for the chassis.

An extremely narrow cross-section engine is optimal for both a reduced frontal area and associated aerodynamic efficiencies, as well as rider comfort – allowing for airflow between the engine and rider.

The daunting task of designing a clean sheet engine is therefore necessary, given the specific set of requirements. Our engine represents a logical and natural evolution of the Henderson, Bugatti, Pratt and Whitney, Rolls Royce, and Hispano-Suiza engineering legacy.

**“I sell engines, the rest of the car I throw in for free.”**

**– Enzo Ferrari**

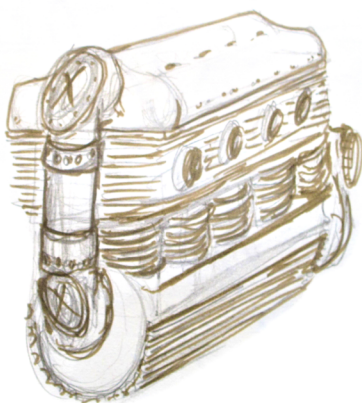

Engine Drawing - 2004

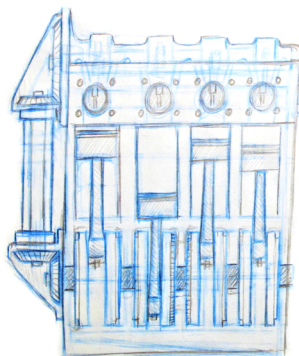

Engine Drawing - 2008

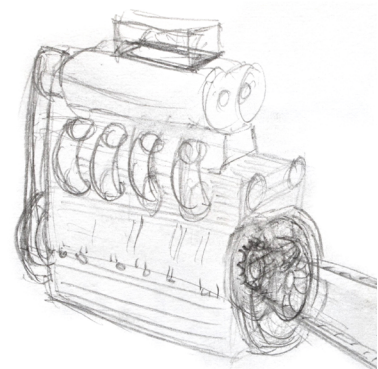

Engine Drawing - 2009

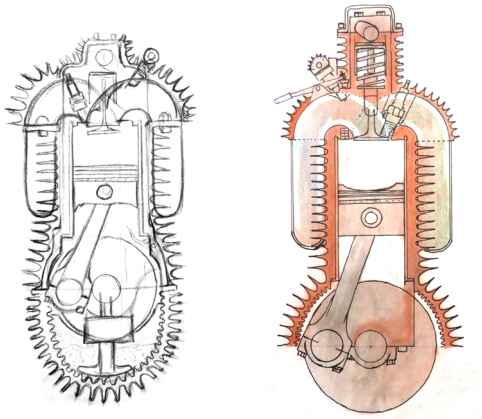

Engine Drawing - 2023

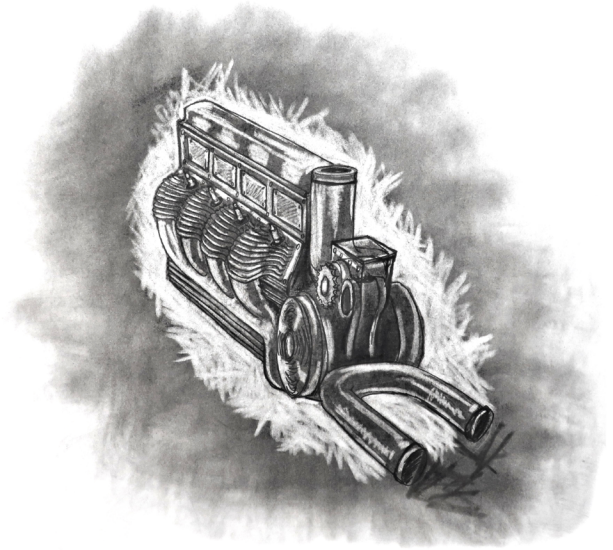

Engine Drawing - 2023

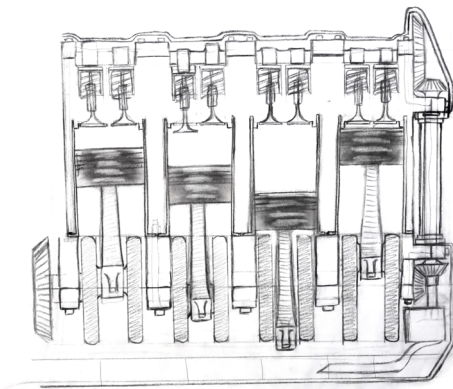

Engine Drawing - 2023

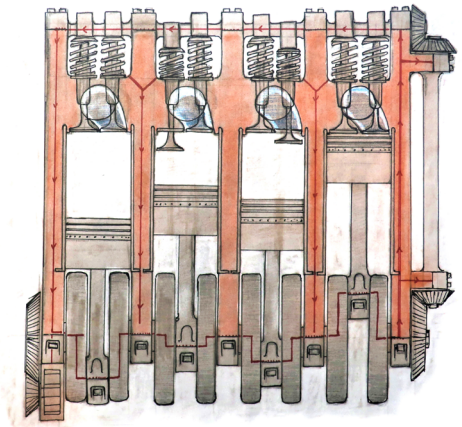

Engine Drawing - 2023

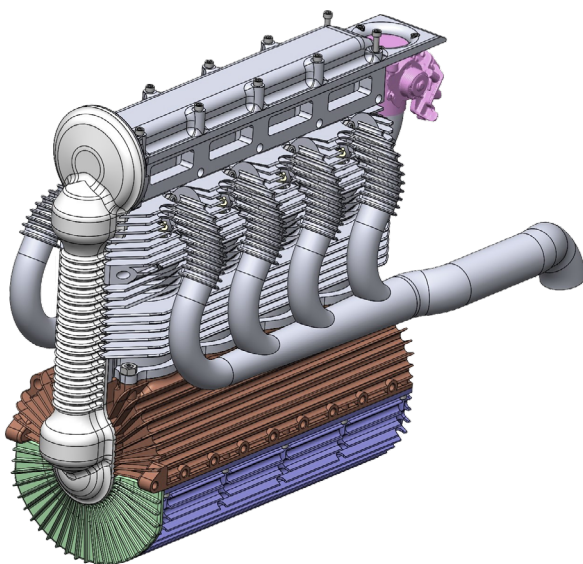

Engine CAD - 2023

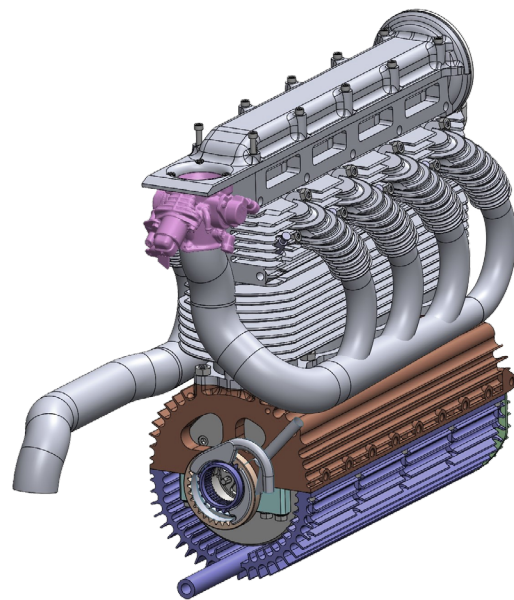

Engine CAD - 2023

# CHAPTER 2

## Transmission

The production of massive torque of our engine only has value when coupled with ease of accessibility. For racing motorcycles, perfectly matching engine speed to road speed to keep within a narrow powerband requires many available transmission ratios. Our motorcycle makes no pretense of being designed for a racetrack; therefore, the inverse is true for our use-case scenario. The absolute fewest number of drive gears, coupled with the broadest spread of torque across the rev-range.

A 3-speed transmission eliminates complexity. The philosophy of using the absolute fewest number of moving parts means questioning the rationale of carrying transmission gears that are not frequently used. Our focus is on the durability of those gears that are required for our use-case. Outright acceleration from rest is not as important as carefully matched ratios for low speed in-town cruising, highway speeds, and appropriate interstate speeds.

Our transmission is a hybrid of constant mesh and sliding mesh systems. First and third gear are in the constant mesh configuration, while second gear is sliding mesh. The antique nature of the sliding mesh necessitates a separate spring drive cush built into the countershaft gear to reduce impact to the second speed gear set. The benefit of this simple system is that there is now only one shifter fork and no shifter drum or plate. The need for a complex shifting pawl and ratchet are now deleted in favor of a simple and robust dual detent system. One adjustable tension detent at the shifter fork and one at the tank shift lever gate. Vertically stacked mainshaft and countershaft satisfy the need to raise the swingarm pivot and concurrently lower the overall center of gravity.

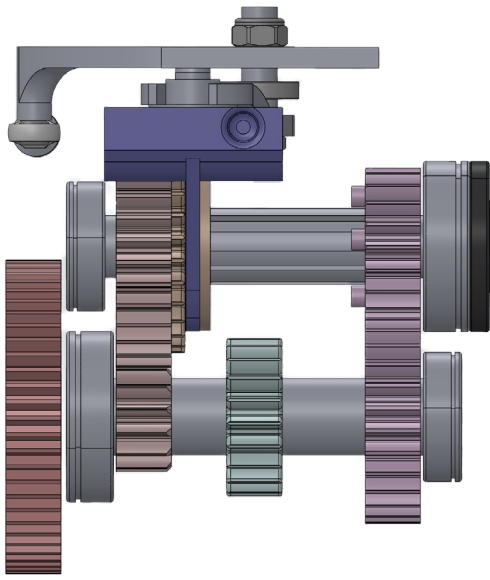

1st Gear

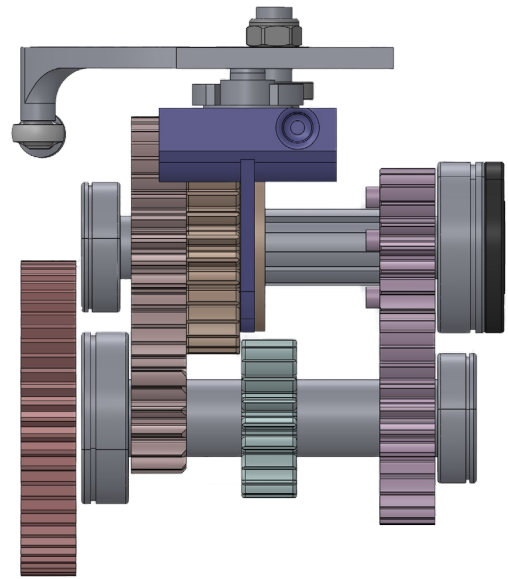

Neutral

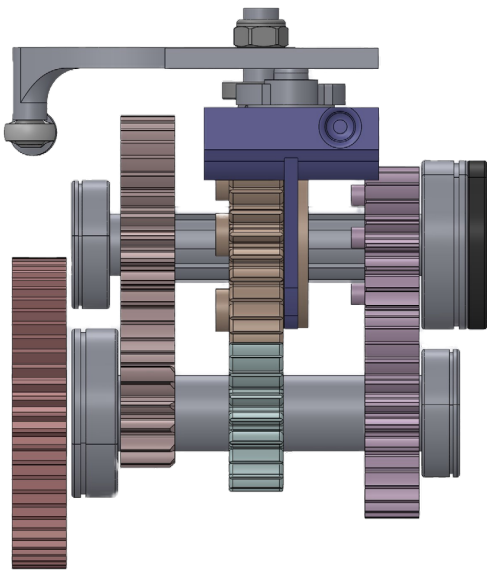

2nd Gear

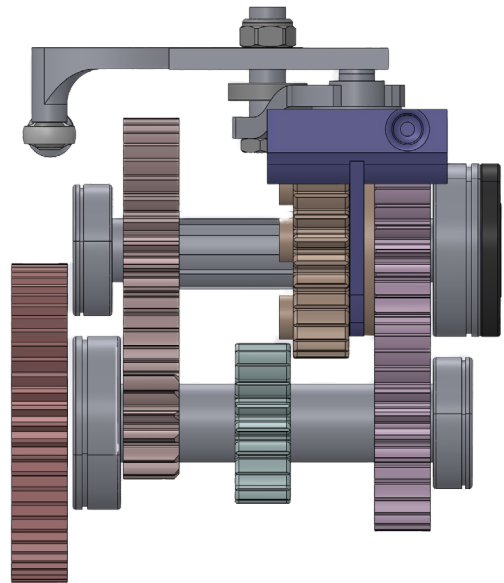

3rd Gear

In addition to a simplified transmission gearset, a centrifugally actuated clutch is utilized. The modern centrifugal clutch coupled with a sequential gearbox eliminates the need for complex traditional automatic transmission assemblies. Our simple system does not rely on a torque converter, valve body, pump, and internal clutches, yet still has the advantage of “twist and go” ease of operation that many find so appealing with modern battery/electric motorcycles.

The deletion of a manually operated clutch, and minimal shifting requirements allows the placement of the shifting lever on the top of the gas tank. Traditional, American style tank shifting with the left hand, without the need for an intimidating foot clutch can be achieved with a fuel injection/ignition timing switch attached to the mechanism. This switch defaults engine management to the “idle” setting and consequently disengages the clutch allowing for the smooth selection of appropriate gear, and reengages upon electric switch confirmation of proper engagement and throttle torque request. Gear selection is therefore a deliberate, thoughtful, and tactile event that enhances the pleasure of connecting with the machine.

For most modern motorcycles there is a disconnect between the concept of a luxury item and a luxury experience. Henderson achieved excellent results, even by modern standards, with this same basic formula. Less shifting, more enjoyment of the riding experience, and more available mental bandwidth for focusing on safe operation.



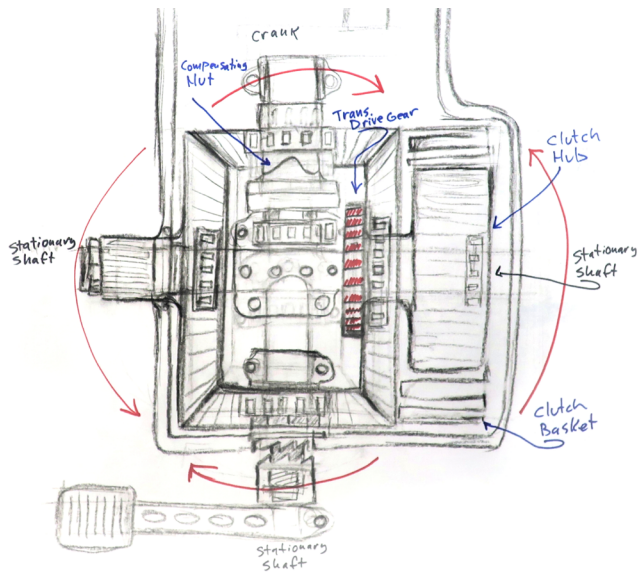

Transmission Drawing - 2023

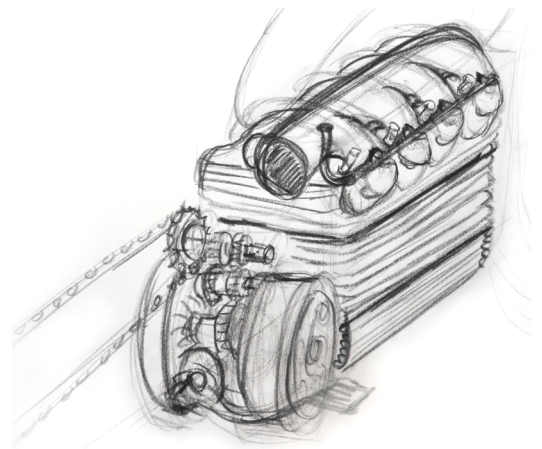

Transmission Drawing - 2023

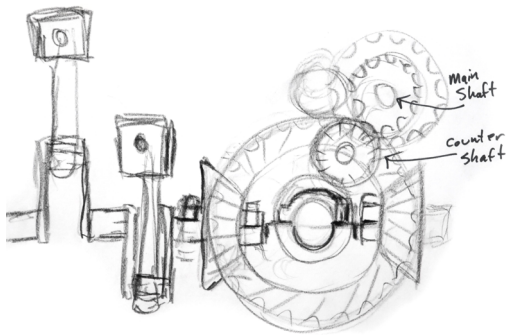

Transmission Drawing - 2023

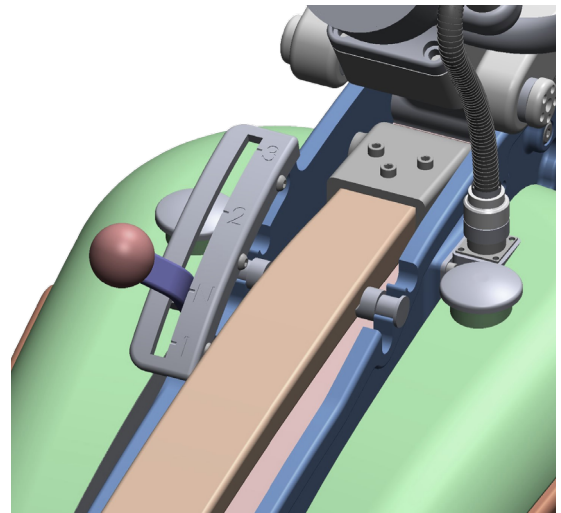

Tank Shifter CAD - 2023

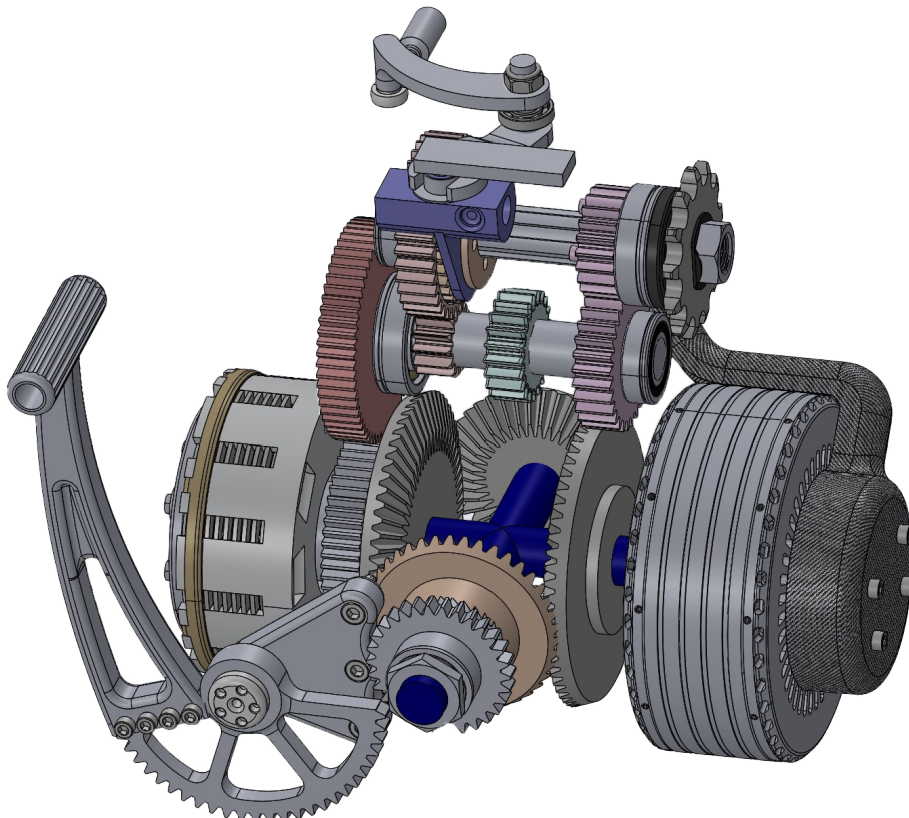

# CHAPTER 3

## Suspension

For the most part, motorcycle suspension has been a process of refinement post WWII with telescopic, fluid filled front fork tubes, and coil-over rear shock arrangement. The modern motorcycle with its highly refined version of this system has proven the validity of this formula, but we submit that it has done little to address its underlying weaknesses. Those being:

**Stiction** - The reliance on bushings within the telescoping elements to provide free play between the two, causes minute pauses in motion, especially in directional changes from rebound to compression.

**Torsional Rigidity** - Fork tubes are prone to twisting forces, and rely entirely on the front axle attachment points to counteract rotating along the steering axis.

**Wheel Trajectory Control** - The critical relationship between steering neck angle (rake) and front wheel contact patch yields the trail value. With a linear telescoping front fork (deflection notwithstanding), trail values will always have a non-alterable trail curve to suspension travel ratio when graphed.

**Dive** - Applying force to front wheel brakes results in a high degree of compression of the front fork tubes as the entire mass of the motorcycle and rider now pivots around the abruptly introduced pole of moments around the front axle. Weight transfer vectors greatly reduce the effectiveness of the front suspension by asking the springs to suspend, while concurrently provide resistance to deceleration force.

**No.1**  
features that put **VINGENT** in a class by itself

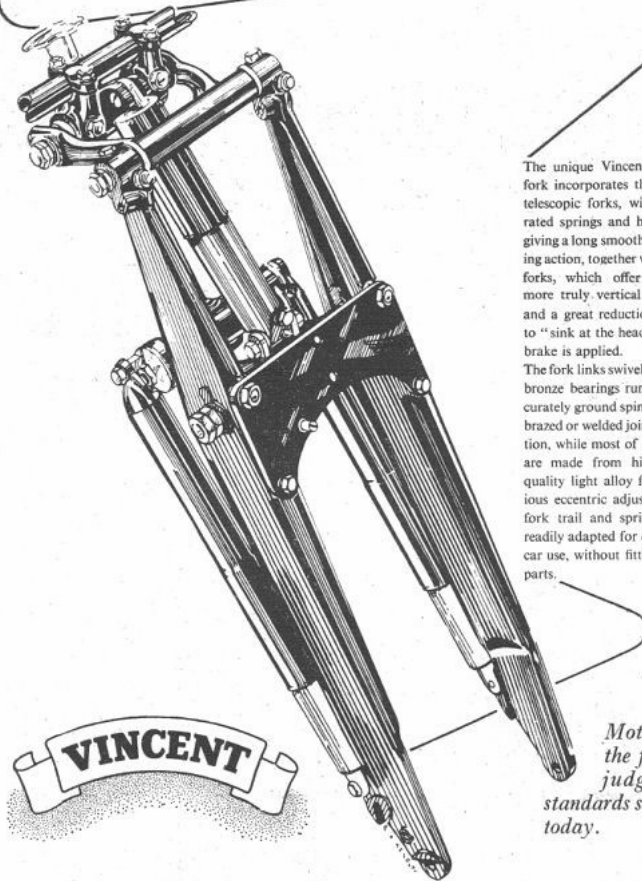

The unique Vincent Girdraulic front fork incorporates the best features of telescopic forks, with their long soft rated springs and hydraulic dampers, giving a long smooth and gentle springing action, together with those of girder forks, which offer great rigidity, a more truly vertical springing motion and a great reduction in the tendency to "sink at the head" when the front brake is applied.

The fork links swivel on self-lubricating bronze bearings running on hard, accurately ground spindles. There are no brazed or welded joints in the construction, while most of major components are made from high grade aircraft quality light alloy forgings. An ingenious eccentric adjustment enables the fork trail and spring strength to be readily adapted for either solo or sidecar use, without fitting any additional parts.

*Motor cycles of the future will be judged by the standards set by Vincent today.*

Vincent Girdraulic Front Suspension

Currently an anachronism, the girder style front fork does have advantages, especially with the application of modern materials, bearing surfaces, and fully understood geometries.

Stiction can be greatly reduced with the use of a multi-link front fork that does not rely on isolating bushings for the tubes to telescope smoothly. Multi-link front suspension systems have inherent torsional rigidity, and when properly tuned, are anti-dive as much of the load applied during braking is transferred to the chassis via linkage, bypassing the spring.

As an added benefit of a multi-link type front suspension, front wheel trajectories can be altered by varying length and placement of the connecting links. This trail value fine tuning has the advantage of altering trail values for any given suspension setting. Expressed as a graph, more or less trail can be achieved for any given suspension compression value, as desired, without the constraints of a linear telescoping front fork. Ideally, the graph will yield an initial scrubbing of trail within the first inch of suspension travel, and then a leveling and stabilization of the trail value throughout the remainder of travel. The “feel” of maneuverability with reduced trail will be maintained, without the exponential loss of stability.

Magnolia 4 Trail Graph - 2023

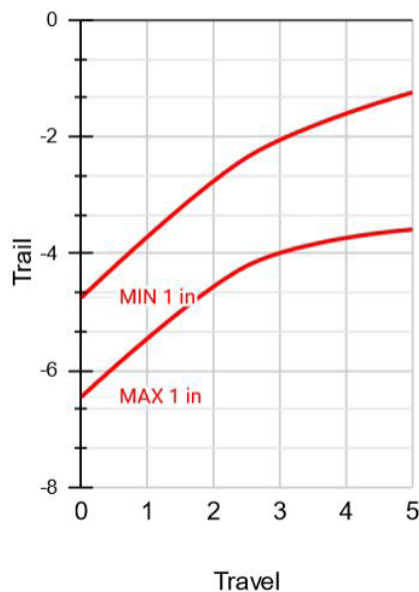

Trail adjustment on the motorcycle can also be easily manipulated by the employment of a sliding tuning block to satisfy varying conditions, and rider preferences. This system alters the effective length of the control arms. To be able to accurately design the initial trail values, the trail value calculator will be utilized to establish a baseline geometry that can then be altered to taste by the end user. A library of parts, the trail value calculator, and years of experimentation are currently on hand.

As well as front suspension, motorcycle rear suspension design was also still in its infancy when the last of the Indian 4-cylinder machines rolled off the line, and the behavior of rear suspension systems under acceleration was completely misunderstood.

It was not until the late 1960's that engineers became vaguely aware that the relationships between swingarm angle, center of gravity, and spring geometry would determine chassis attitude under acceleration. With the advent of the very powerful Japanese inline-4, the deficiencies of previous geometries became apparent.

Our motorcycle will incorporate a swingarm up-angle of approximately 12 degrees static. This fairly shallow angle is possible with the placement of the engine as low as is practical, yielding an extremely low overall center of gravity. Our swingarm angle is enough, however, to vector acceleration forces through the structure of the arm itself, causing slight rebound of the rear suspension under acceleration. This relationship is only made possible by stacking the transmission mainshaft and countershaft vertically to locate the front drive sprocket high, relative to the engine crankshaft centerline. A proprietary engine and transmission must therefore be designed from a clean sheet to satisfy the requirements of proper rear suspension hard points.

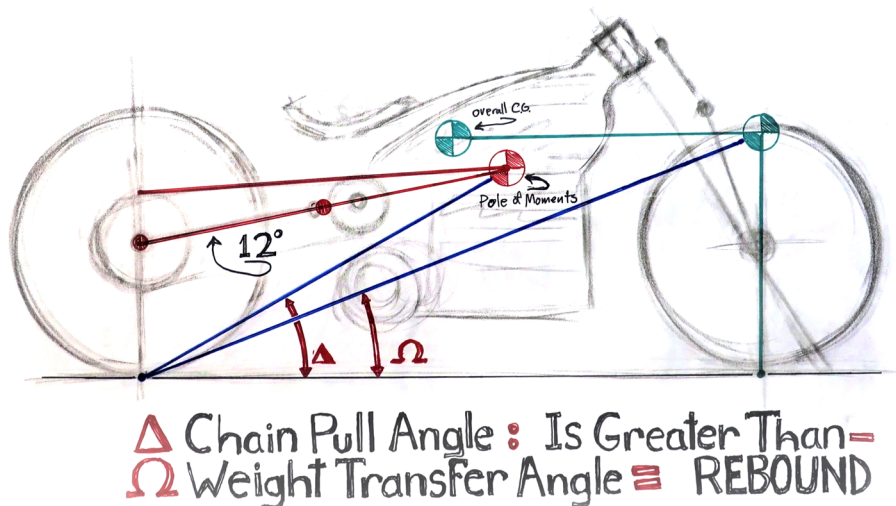

The suspension system of the Magnolia 4 uses hydro-pneumatic shock absorbers on each individual girder blade and an additional one under the seat. These lightweight air spring units have a low impact on unsprung weight while still offering the full range of compression and rebound damping. With 5 inches of total wheel travel at the front and rear, the addition of a sprung saddle yields a total “felt” suspension travel of over eight inches. The entire suspension system uses no bushings as all pivot points are isolated with needle roller bearings that yield precise, smooth control.

Extrapolating the “fewest number of moving parts” theme covered in the chapter on the engine, bilaterally symmetrical suspension members have been designed specifically for our unique set of pivot points. Much design energy has been spent on these parts, but these identical suspension members are used on all four corners of the motorcycle. This effort delivers not only advantages in scalability but also to add visual cohesion to the overall aesthetic, the essence of minimalism.

**“When everything goes right, a mobile is a piece of poetry that dances with the joy of life and surprise..”**  
**– Alexander Calder**

William Henderson did not have access to the subsequent decades of suspension research and design, but was also limited by available materials. Multi-link front and rear suspension with modern geometry still has its own specific set of challenges. Mass centralization and un-sprung weight are challenges to overcome. For solutions, we turn to modern materials.

Universal Girder Blade

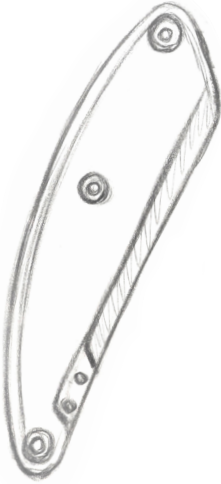

2003 Wraith

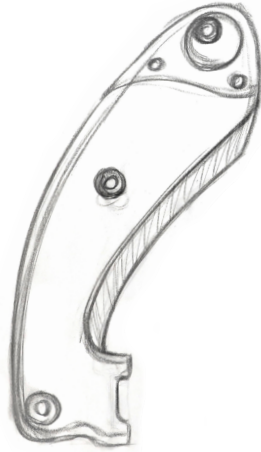

2013 Legacy



2020 Curtiss



2023 Magnolia 4



2015 Bienville Legacy (left) and 2022 Curtiss One (right) featuring identical front and rear suspension members

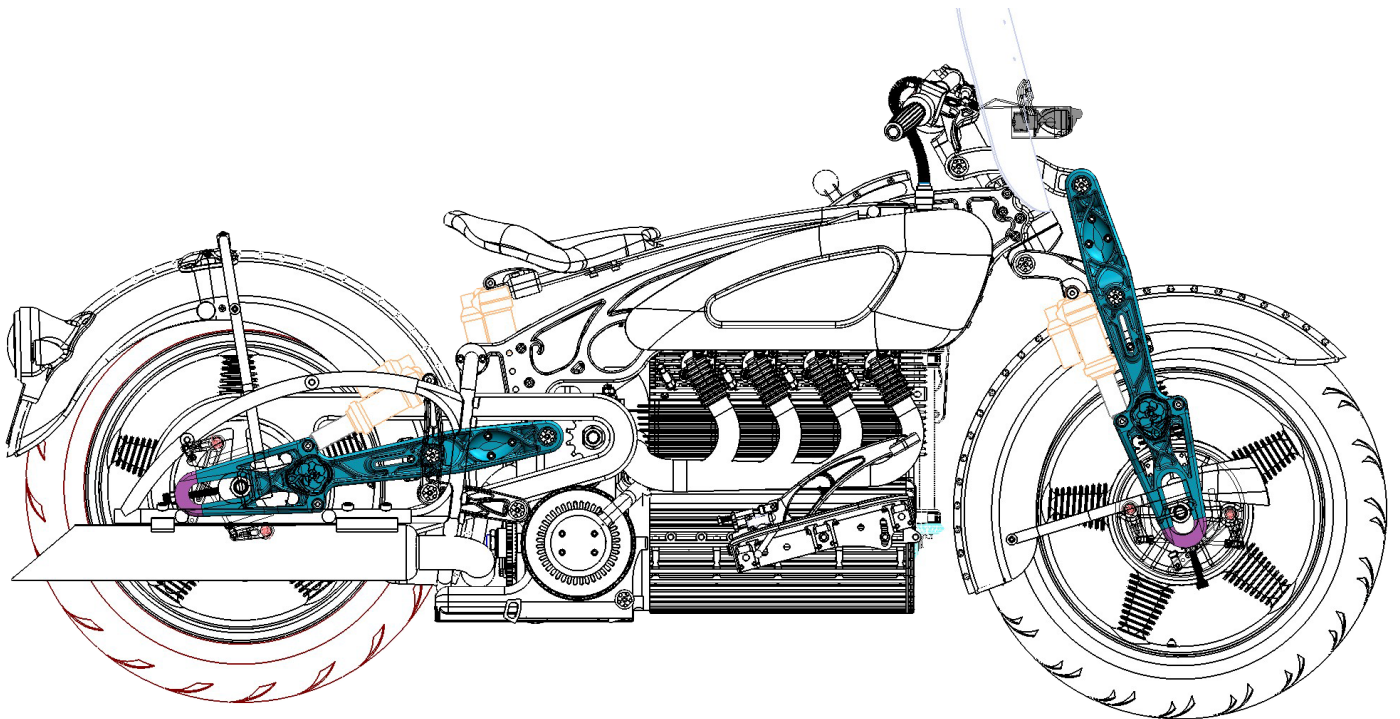

# CHAPTER 4

## Materials & Manufacturing

Considering the unavoidable weight of a powertrain designed to last for generations, and serve as the platform for other cycle parts and suspension, the concept of “adding lightness” must be observed.

Titanium selection for the project is of two grades Grade 2cp (commercially pure) and Grade 5 (Ti6Al4V). Grade 2 Titanium is the most commonly available of the un-alloyed and its oxygen content giving it good ductility and high tensile strength, an excellent all-round material for brackets and suspension components, especially when water-jet cut and bolted together, avoiding welding (and the associated embrittlement) when not necessary. Grade 5 Titanium is alloyed with Aluminum and Vanadium and is the strongest readily available alloy. An excellent choice for axles, suspension pushrods, and fasteners. The weakness of Titanium is its extreme sensitivity to ambient oxygen when welded, and difficulty in machining (tendency to gall and spring-back). The benefits of high strength to weight ratio and resistance to corrosion make it an excellent, but challenging choice for structural pieces.

The proliferation of 5-axis CNC machines will allow for previously unattainable intricate shapes carved from homogenous billet blocks. Our engine will be machined from a 6000 series aluminum alloy with the highest level of integration of block, cylinder, and head. Fewer junctions, that are reinforced with massive locating lugs, yield more stability and less distortion as the assembly reaches operating temperature. The goal is maintaining a stable platform for cycle parts and suspension attachment points. Our Engine is truly a structural component. The manufacturing techniques required to execute the complex structures of the engine in low volumes have only been commercially viable in the 21st century.



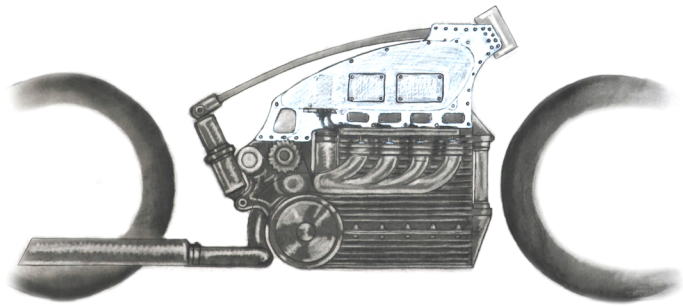

Engine As Structural Member Drawing - 2023

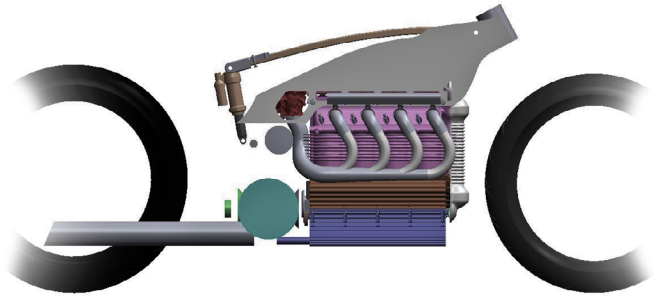

Engine As Structural Member CAD - 2023

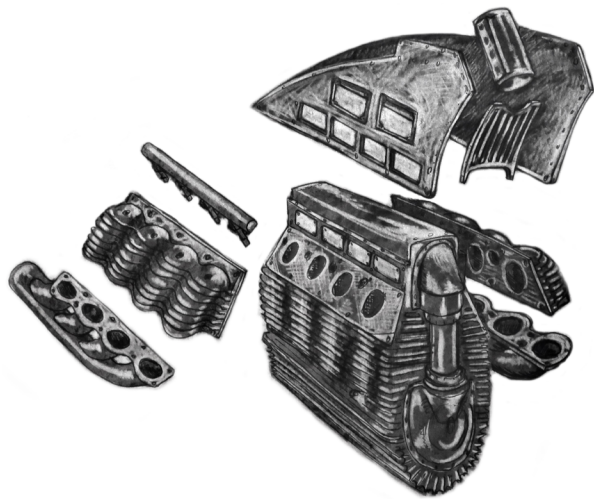

Engine As Structural Member Drawing - 2023

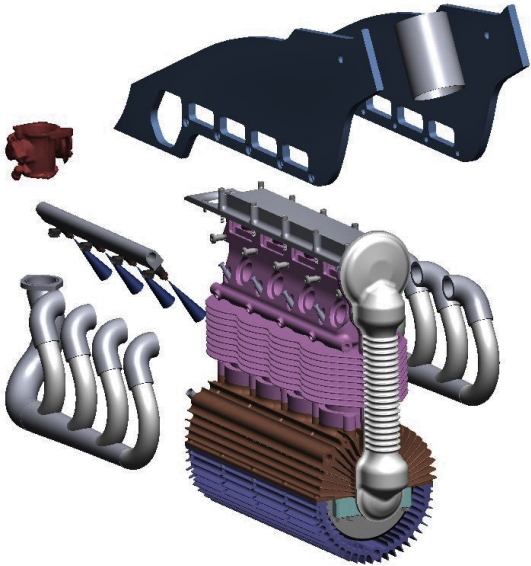

Engine As Structural Member CAD - 2023

# CHAPTER 5

## Ergonomics

On a bicycle, human interface is restricted to grips, seat, and pedals. Any further contact such as shins, thighs, calves, and ankles would result in contact points that generate friction and impair the act of pedaling. Obviously, a motorcycle pedals itself but the origin of the species is exactly that-a bicycle with a little motor that helps to propel it. Unlike a bicycle, friction and contact points between rider and motorcycle are not detrimental.

When mounted on just about any modern OR vintage motorcycle, a variety of textures and unreconciled materials are contacted during normal operation: vinyl of the seat, painted plastic of bodywork, aluminum of the chassis, various engine components, and painted steel of the gas tank, with huge gaps in between each material transition. This is the lingering and incorrect application of bicycle-style ergonomics to motorcycles that we will rectify.

Known as “counter-steer”, a motorcycle is steered by forces applied to the front fork through the opposite hand grip of the directional change, but this motion is supported by lower body contact with the seat, tank, and foot pegs as well. Part of the magical experience of riding a motorcycle is that somehow, we humans do this intuitively. Perhaps it is part of a genetic knowledge that is formed from the intersection of brachiation and bipedalism that our species inhabits, perhaps other species possess this intuition as well, regardless, it takes very little brain power for a human to master the complicated physics of the counter-steer. Enhancing the flow of information exchange between the chassis and lower body will support steering, acceleration, deceleration, and lean angle confidence.

Adjustability is an essential component of good ergonomic design. Human bodies come in an astounding variety, and being able to accommodate as many as possible means tremendous variation in seat

height, fore/aft movement, adjustable reach to the hand grips, grip angle, and foot rest location. All these adjustable features must be separate from the suspension geometry in order to maintain consistent chassis performance. One thing that ALL human bodies can agree on is a slim profile in the seating area. A narrow motorcycle between the legs is analogous to the concept of interior roominess of an automobile.



1936 Harley Davidson Knucklehead

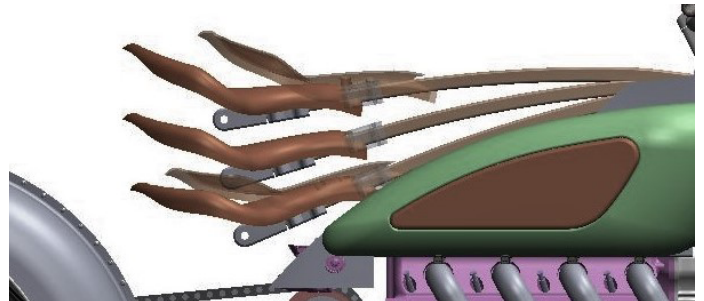

Adjustable Seat CAD - 2023

One very important facet of antique motorcycle ergonomic design that does resonate for our new motorcycle is the concept of a sprung saddle. The lack of rear suspension on pre-war American motorcycles, necessitated a separate suspension system dedicated to the rider. Even when rudimentary rear suspensions were incorporated in the 1950's, the traditional sprung saddle was retained. Harley Davidson used a separate rider suspension system from 1903 to 1984 when it was abandoned for styling reasons, not for any argument against its utility. Our new motorcycle will revisit this ancient, but delightful concept by applying modern materials and suspension components in furtherance of the pursuit of the ultimate long distance touring experience.

**“Good artists copy, Great artists steal.”**

**– Pablo Picasso**

A lightweight composite leaf spring suspends the seat. The rate of the spring can be easily adjusted to accommodate various rider weight with a notched adjuster near the steering neck. This adjustment is done in conjunction with a variable position hydro-pneumatic suspension shock absorber that is also able to increase or decrease rate with air pressure, boosting the capacity to carry load. The seat mount itself is adjustable along the body of the leaf spring to increase or decrease the reach to the handlebars for a range of over 7 inches. Therefore, initial seat height (27 to 32 inches), and overall seat travel (0 to 4 inches), are infinitely adjustable for every rider, in either solo or 2-up configuration.

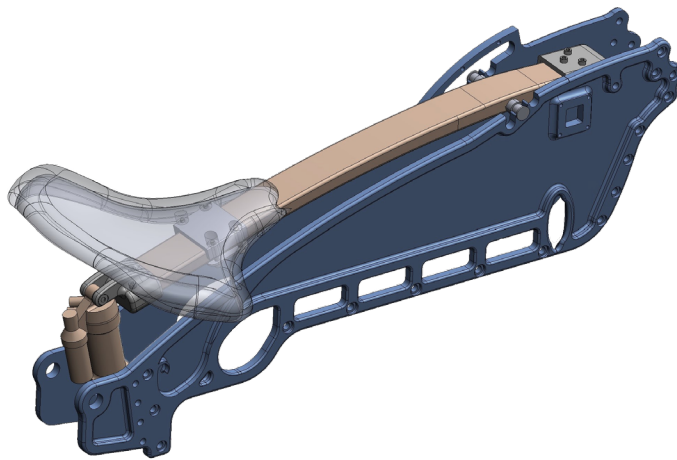

Generous floorboards have been a staple feature for American touring motorcycles since the invention of the genre. Our floorboards have the added benefit of being completely adjustable. Fore and aft positioning is available with the row of bosses machined into the engine case. The wide range of floorboard angle adjustment via adjusting slots is independent of the brake lever mechanism, giving a huge range of articulation to satisfy almost every human morphology.

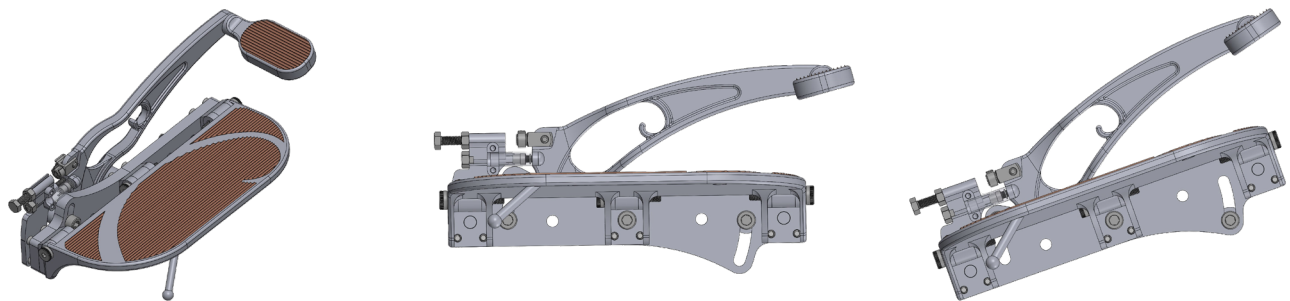

# CHAPTER 6

## The Century Concept

The final, and most important design philosophy of our motorcycle will be the construction of a machine that will stand the tests of time. A machine that can remain unused for one hundred years, then be easily re-commissioned is a testament to quality of construction and foresight of design on a generational scale. Considering the ravages of Time, printed circuit boards, corrosive fluids, and the weakness of electric storage must be addressed.



ABS / Traction Control  
Computer Housing

A fuel injection system, while relying entirely on electronic control, can be made to hedge against obsolescence by using the simplest and most universal components. Understanding the fragility of our injectors, ECU, airflow sensor, oxygen sensor, temperature sensor, and throttle body, mandates that the replacement of these components will eventually be necessary. Access to the injection program must also be unrestricted and open-source. While mechanical carburation has been considered, the drawbacks of emission regulation, and shelf-life of corrosive modern petroleum, tip the scales in favor of the most rudimentary injection system possible.

Corrosive hydraulic brake fluid must not be utilized, mandating the re-imagining of another successful antique recipe for survival, the cable operated brake. The mechanical drum brake has been overlooked for too long due to a broad acceptance of its inadequacy. The enemy of efficient drum brakes has always been the accumulation of heat, and the subsequent “fade” in consistent performance. The acceptance of this view has, however, been based on the systems use in conjunction with the contemporaneous practice of fitting wire wheels. The common adoption of monolithic cast wheels on motorcycles was just a few years behind the adoption of hydraulically operated disc brakes in the motorcycle industry. Therefore, the combination of drum brake with heat absorbing cast wheels was not developed.

The greatest heat-sink on a vehicle is in fact, the wheels. Ettore Bugatti understood this concept, and in 1924 produced the first integrated brake drum/wheel combination on the legendary Bugatti Type 35. Our aluminum wheels will be designed to house a pressed-in, cast iron braking surface. The more aggressively the motorcycle is used, the more cooling airflow organically occurs, radiating the corresponding heat generated. The addition of modern needle roller bearings to replace bushings in the brake shoe camshaft, and experimentation with adjustable lever ratios, bring the power and “feel” of drum brakes into the modern era. Designing and manufacturing of one of the most fundamental components, rather than utilizing currently available wheels designed for hydraulically actuated disc braking, is therefore necessary.

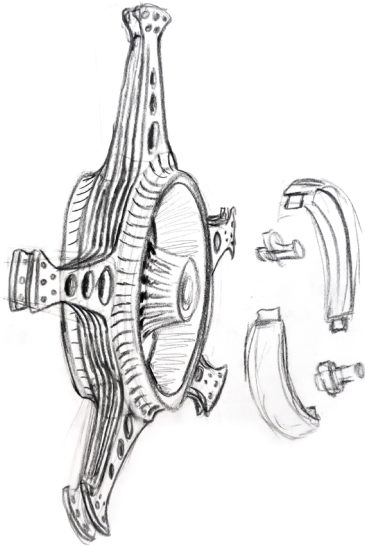

Monolithic Aluminum Wheel with Integrated Brake Drum Drawing - 2023



Monolithic Aluminum Wheel with Integrated Brake Drum CAD - 2023



Monolithic Aluminum Wheel with Integrated Brake Drum CAD - 2023

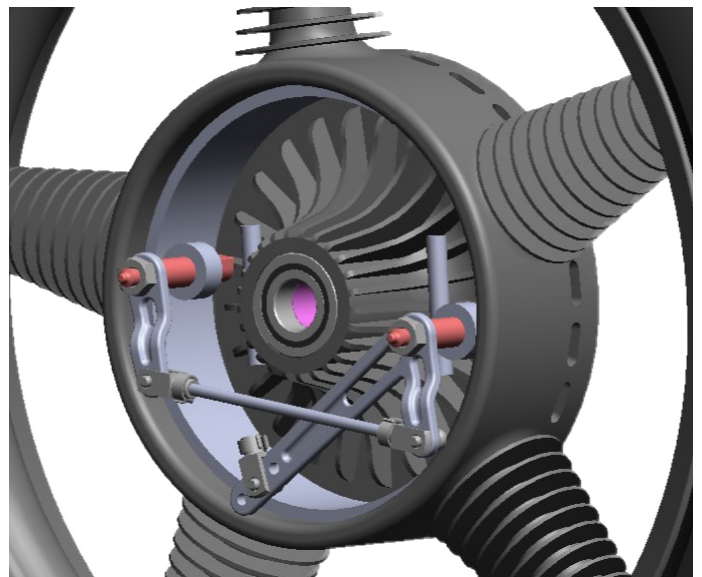

Monolithic Aluminum Wheel with Cooling Turbine - 2023

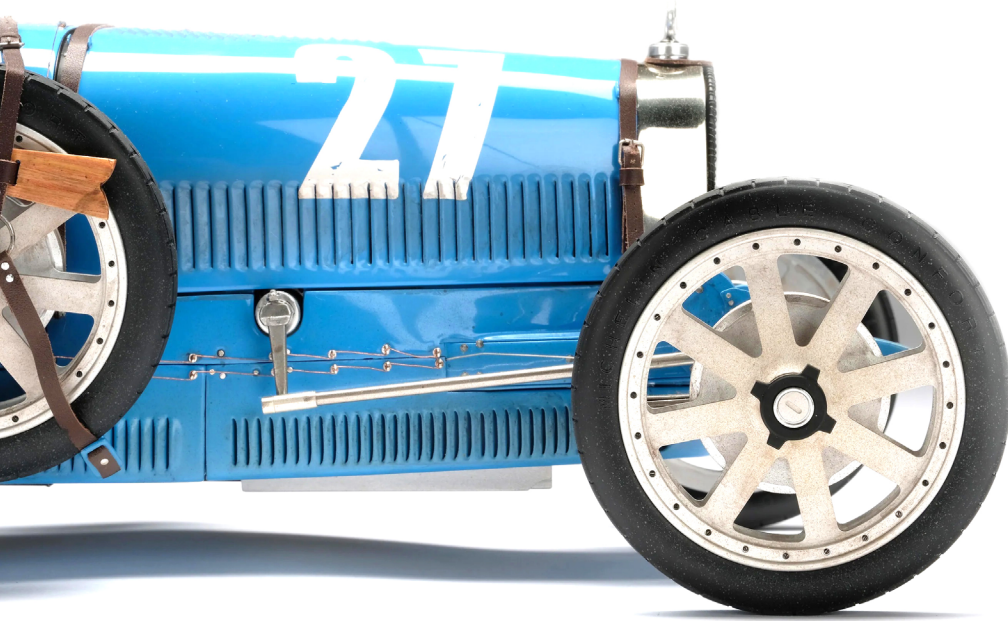

1926 Bugatti Type 35T

**“There is nothing that is too beautiful, nothing that is too expensive.”**

**- Ettore Bugatti**

The act of turning bio-mechanical energy into a self-sustaining, chemical-electro-mechanical reaction is a lost art form. In the mid 1960's the adoption of electric start by Harley Davidson and Honda signaled the demise of the Kick-start only motorcycle, and by 1980 it was considered an anachronism. The complexity of the electrical system doubled, as well as adding weight. Starter motors, solenoid switches, heavy battery cables, ring gear, starter sprag clutches, and large batteries were now necessary components. Adding these systems to a motorcycle increased convenience, but at the expense of long-term reliability.

In the golden age of pre-war motorcycles, a very simple electrical system was used. A generator was coupled to the engine to produce current for lighting and stored excess electricity in a very small battery. A separate device called a magneto was timed to the engine and produced sufficient current for spark plugs. This stand-alone magneto ignition system does not rely on any form of electrical storage as it produces and distributes current directly to the plugs.



Combining these systems resulted in the mag/dyno, a standalone unit that produces sufficient current for lighting and ignition. Mag/dynos of this type have been used in many industrial applications and occasionally motorcycles of smaller displacement. The challenge will be the construction of a modern mag/dyno that will produce sufficient current for lighting, ignition, and be able to power-up our fuel injection systems fuel pump with one stroke of a kick-start arm. We accomplish this by re-configuring the latest generation of axial flux electric motors, to become axial flux generators. The high efficiency of modern axial flux technologies opens new possibilities for compact and simple electrical/ignition systems that abandon the reliance on a battery completely.

Kick-starting a motorcycle is a romantic statement of self-reliance and authenticity. Manual compression release valves are specified for ease of starting and become part of the ceremony of start-up. In alignment with the overall philosophy of the minimum parts and systems required for motoring, our motorcycle will be kick-start only.



Axial Flux Motor

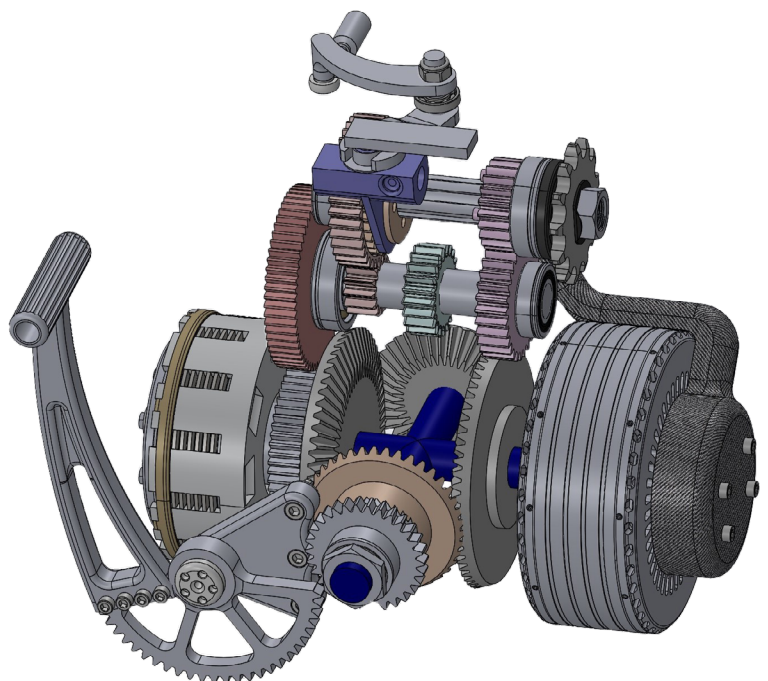

Kickstarter with Axial Flux Mag Dyno

# CHAPTER 7

## Visual Identity

In shaping the visual identity of the Magnolia 4, we started by drawing inspiration from a spectrum of sources, each weaving together a brand that portrays elegance, craftsmanship, and authenticity. On a global scale, we drew creative sparks from the artistry and craftsmanship of Japanese sword engravings, the avant-garde allure of Man Ray's photography, and the world of luxury automobiles exemplified by the likeness of Bentley, Ferrari, Bugatti, and Avions Voisin. We found locally-rooted influence in the sinuous linework of Louisiana Art Nouveau, the nature-bound beauty of Newcomb pottery, the iconic intricacies of New Orleans ironwork, the expressive mystique of Haitian vèvè, and, of course, the predecessor of the Magnolia 4, the Magnolia Special.

Melding these diverse influences paved the way for developing a visual identity that celebrates our melting-pot culture while embracing modern advancements. The Magnolia 4 lovingly pays tribute to its New Orleans heritage and the innovative legacy our city has etched into history. As born and raised locals from the heart of Louisiana, it is our cultural birthright to leverage these native influences in our work.

The interplay of these inspirations results in a distinct visual identity that commands recognition, echoing the exceptionality of the Magnolia 4 itself. In this creative endeavor, our only competition is our own commitment to excellence.

**“New Orleans is not just a city. It’s a spirit, a feeling.”**

**- Tony Baxter**



# MAGNOLIA

BUILT  
TO  
LAST

an enduring love letter to  
all things mechanical

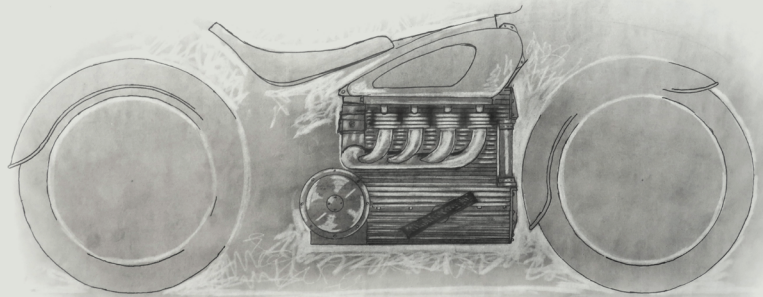

New Orleans inspired. **New Orleans made.**

# INSPIRATION BOARD

## Newcomb Pottery



## New Orleans Ironwork



## Haitian Vèvè

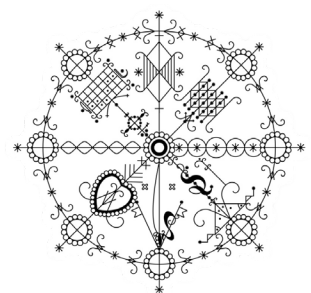
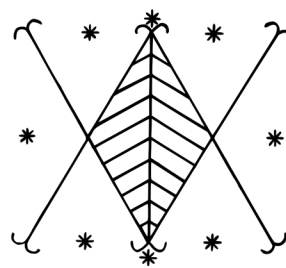
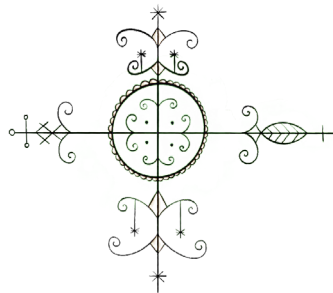
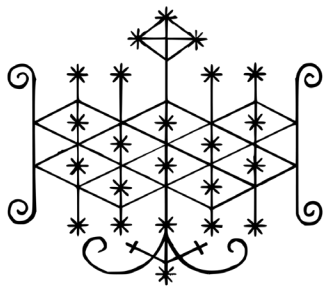

Vèvè of Ogou Badagri, a powerful warrior spirit

Vèvè of Simbi spirits, the guardians of water

Vèvè of Ayizan, the spirit of commerce & markets

Vèvè of Milokan, calling a congregation of deities

## Man Ray Photography



Luxury Automobile Brands

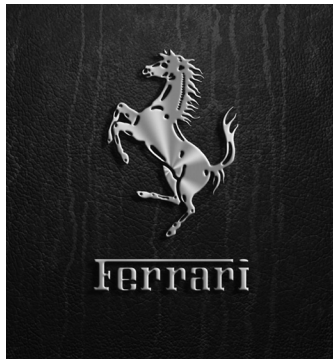

Art Nouveau

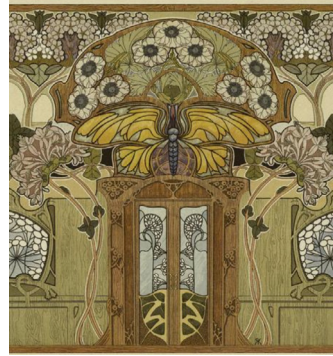

Japanese Sword Engraving (Horimono)

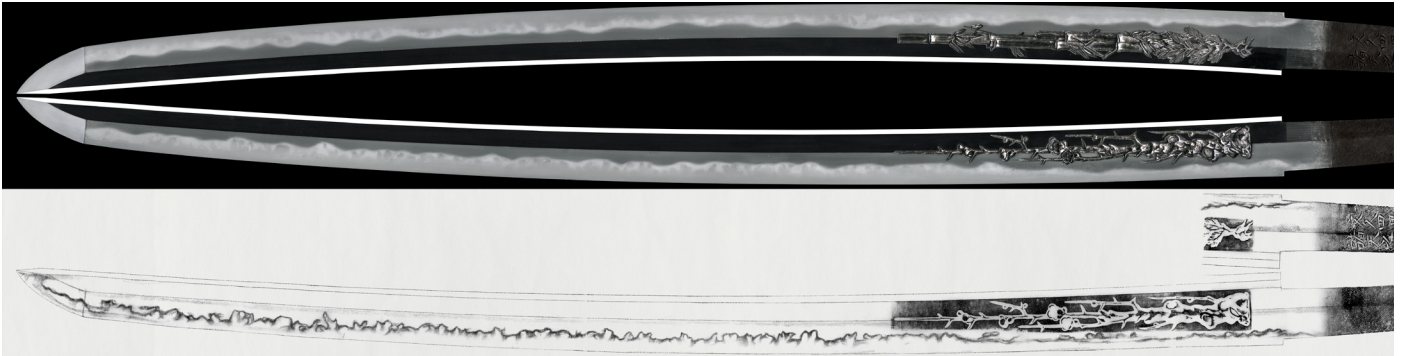

Magnolia Special



# LOGO CONCEPT SKETCHES

First Round of Logo Iterations

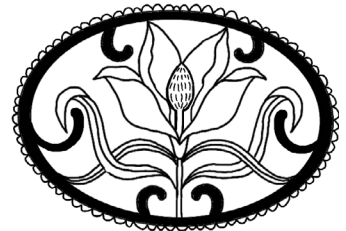
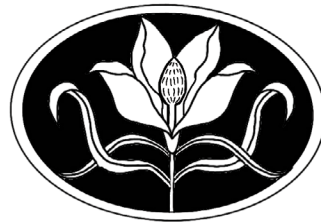
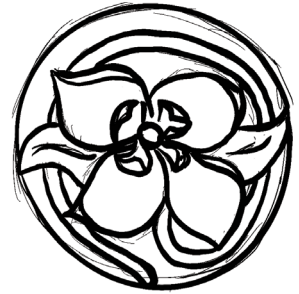
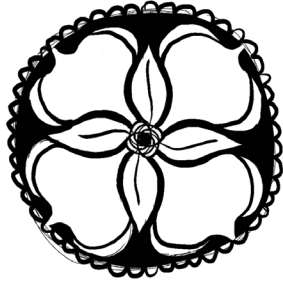
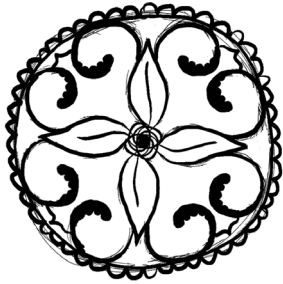

**MagnoliaTV**

**MIV**

**MAGNOLIA**

**M**

*Magnolia*

*M*

Second Round of Logo Iterations



MAGNOLIA

M

Third Round of Logo Iterations



MAGNOLIA

M

# BRAND GUIDE

## Logo

The logomark directly draws inspiration from the curvilinear forms of Art Nouveau, New Orleans ironwork, the dramatic lighting contrast of Man Ray's photography, and the intricate engravings found on Japanese swords, forging an original logomark. Meanwhile, the logotype is a bespoke custom font crafted to blend the timeless charm of Art Nouveau typography with a modern sensibility borrowed from other prestigious automobile brands.

Full Logo



Logotype



Detailed Logomark



Lettermark



Single Color Variations



Minimal Logomark



The minimal logomark will be used in replace of the detailed logomark when under 1.25 inches wide for print and 120px for digital.



# Color Palette

The color palette directly pays homage to the mesmerizing blue, green, and yellow matte ceramic glaze of Newcomb pottery, a New Orleans icon.

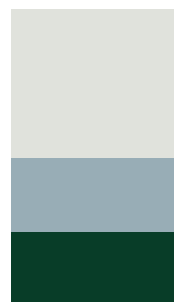
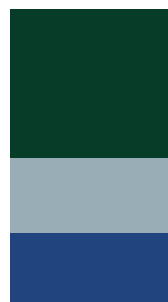
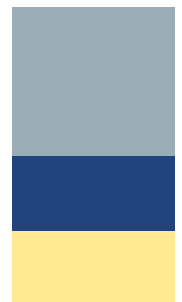
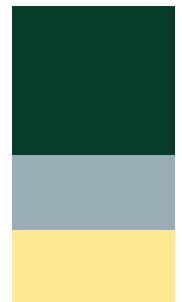
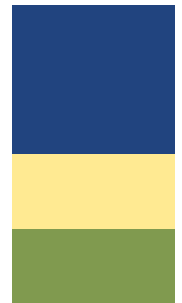

# CONCEPT SKETCHES

1999 - 2023

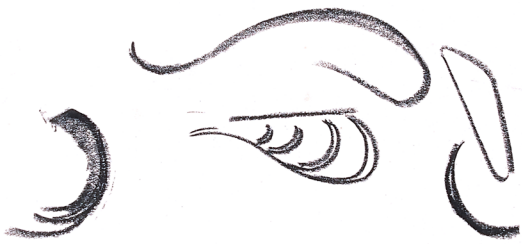

1999

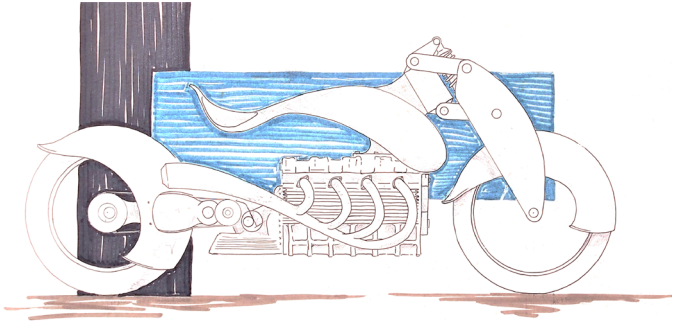

2000

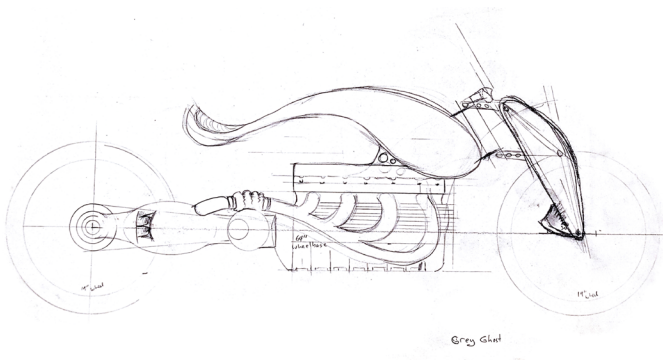

2000



2001

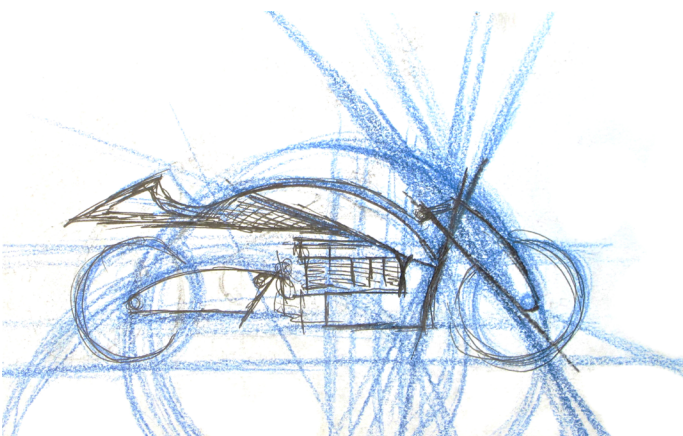

2001

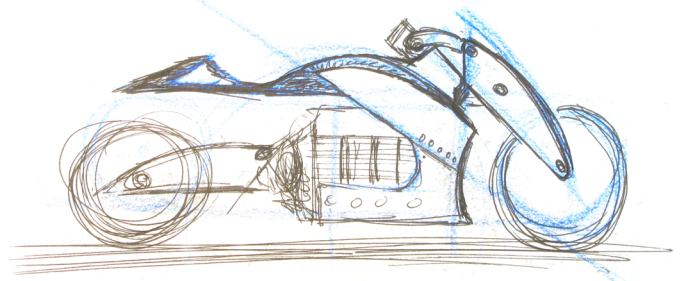

2002

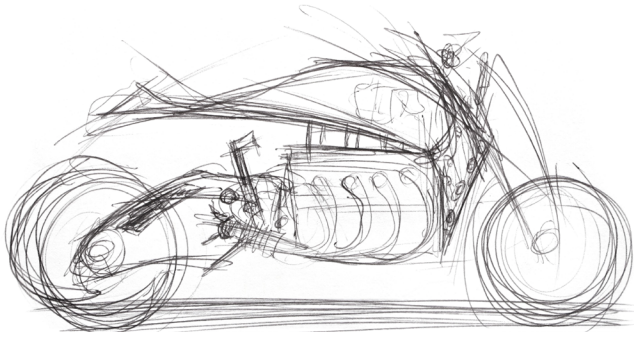

2002



2003

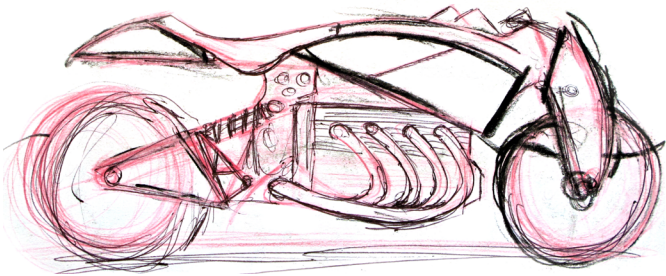

2003

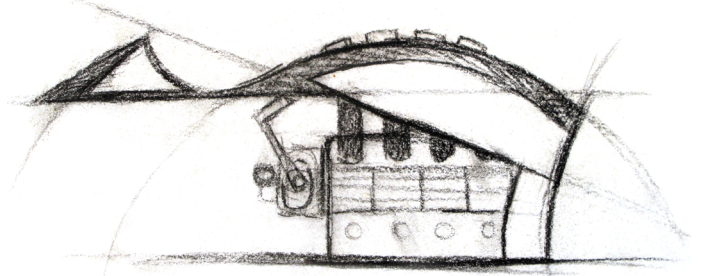

2003

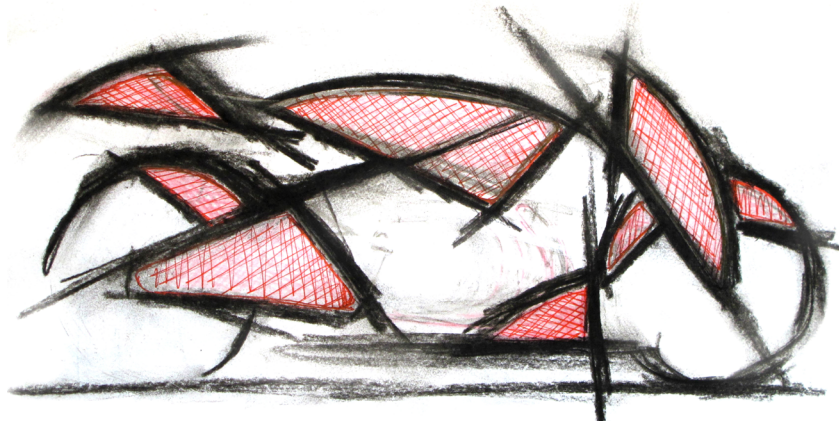

2004

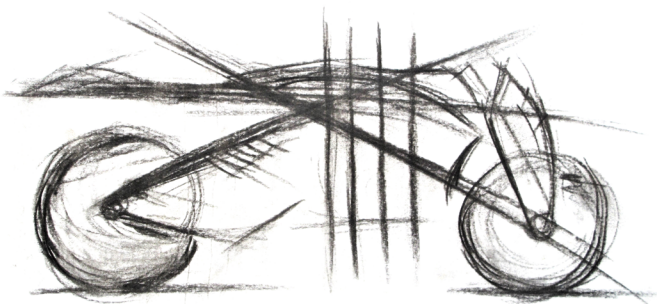

2004

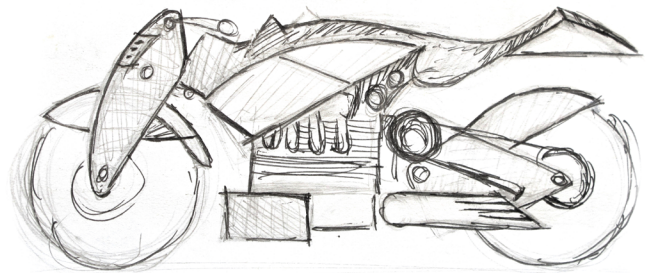

2005



2007



2007

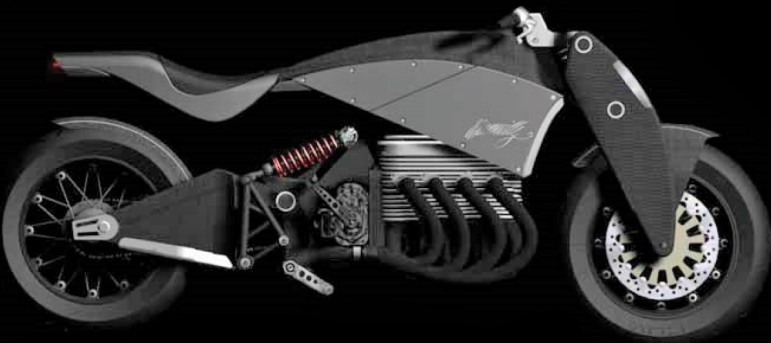

2007



2007

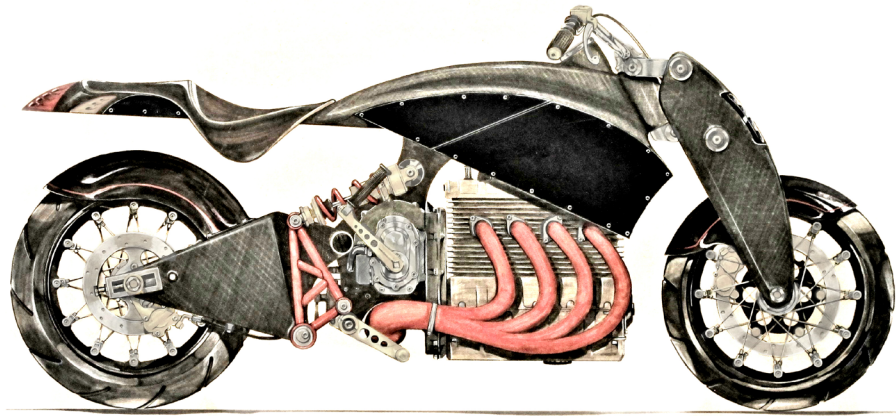

2007

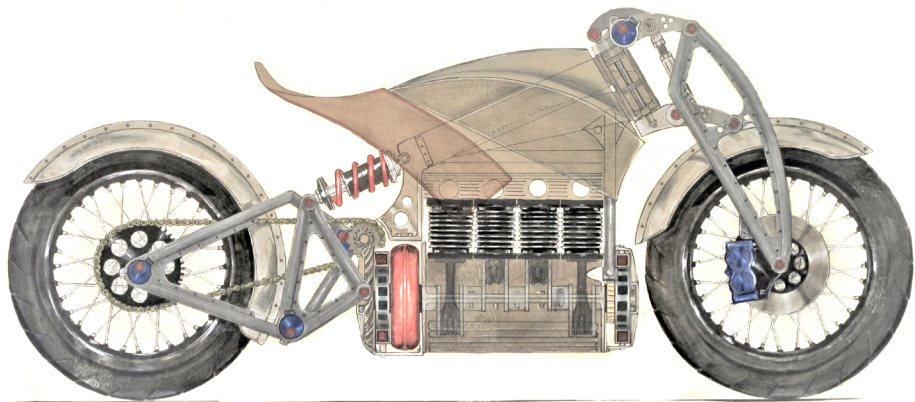

2015

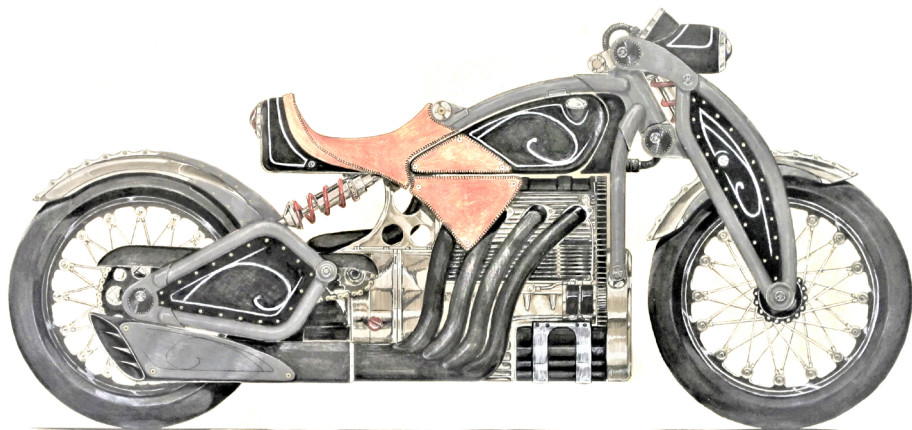

2017

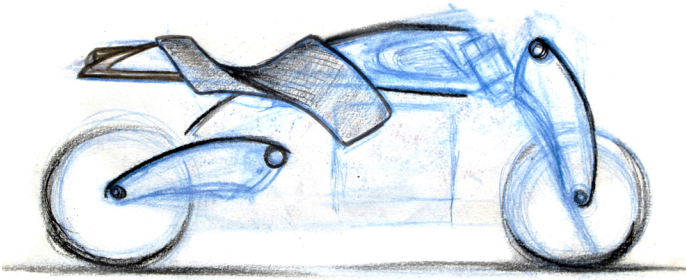

2017

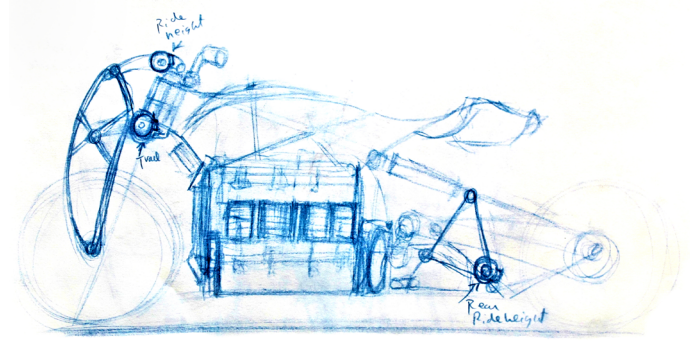

2017

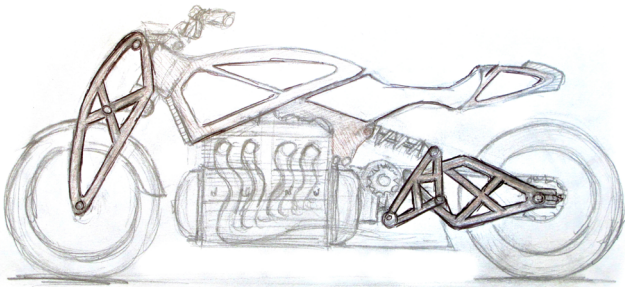

2018

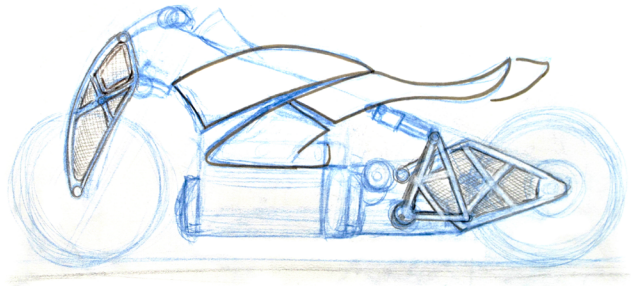

2019

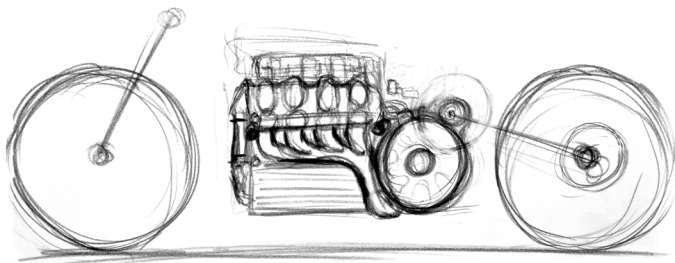

2021

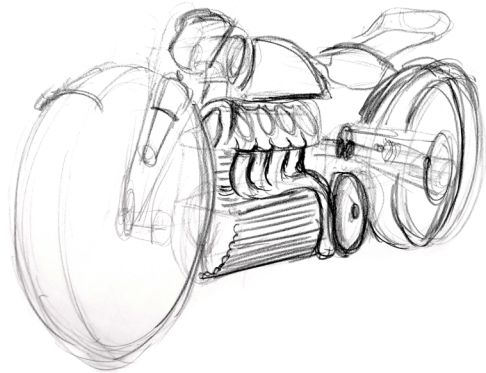

2021

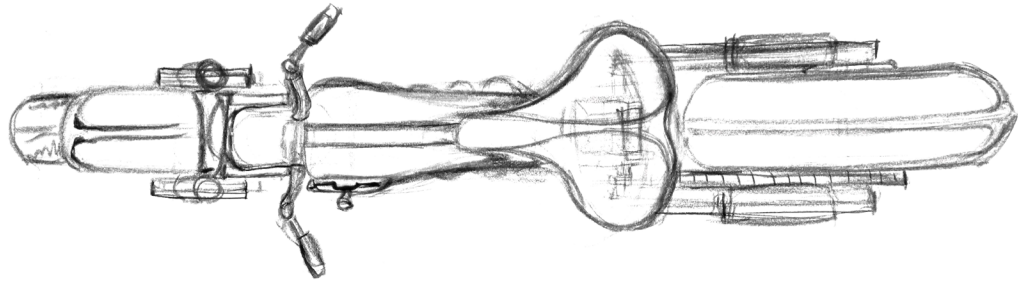

2022

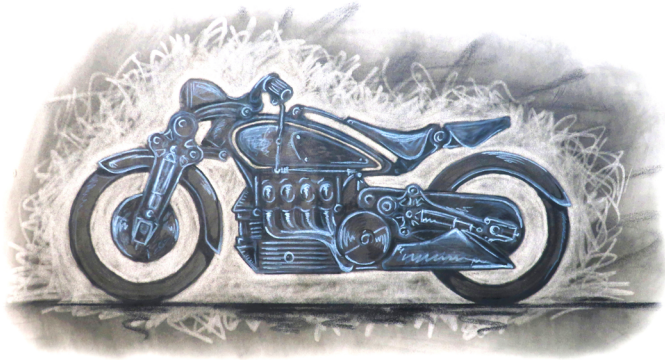

2022

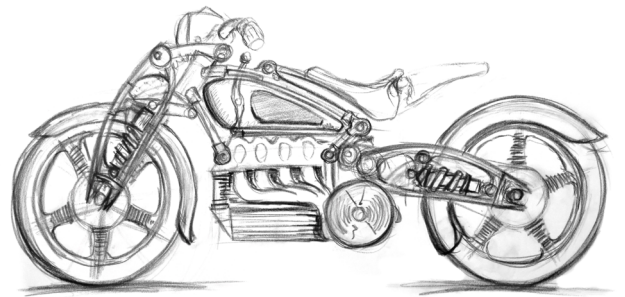

2022

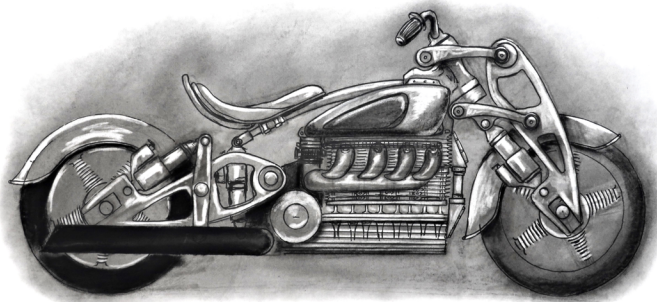

2023

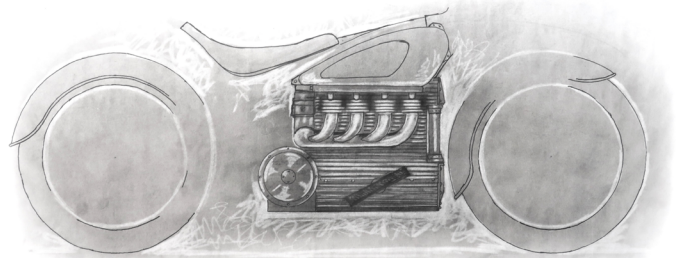

2023

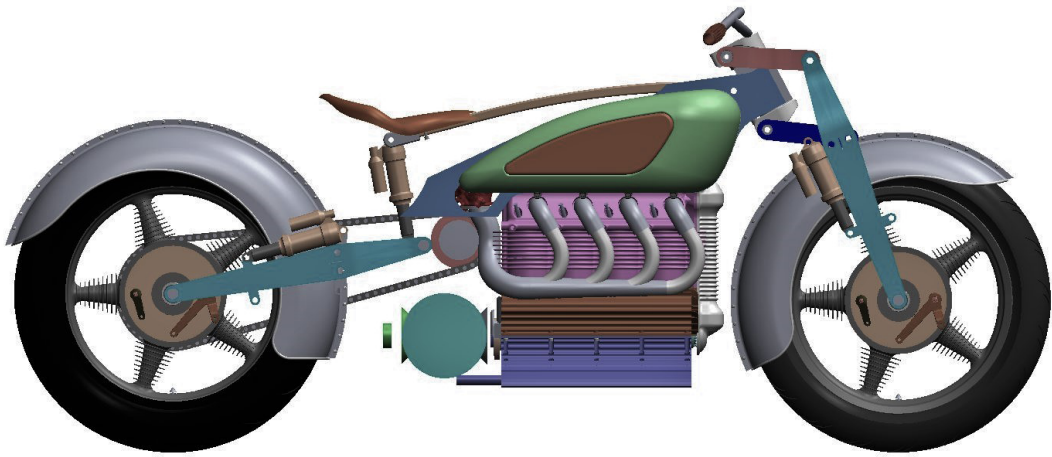

2023

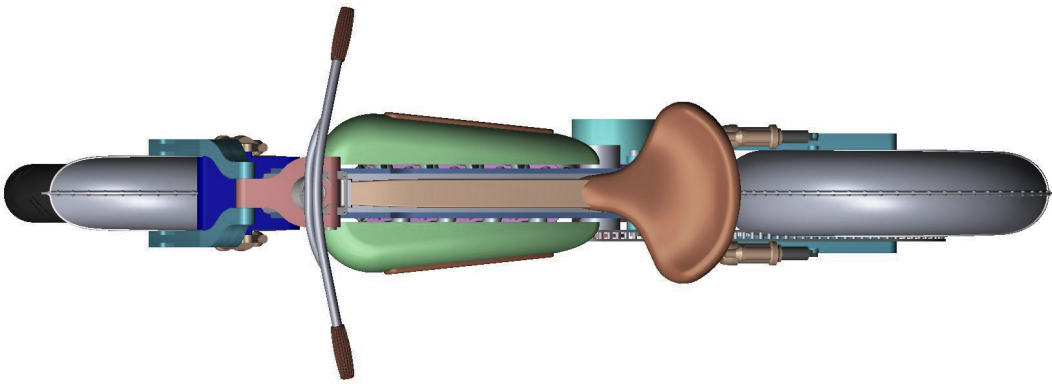

2023

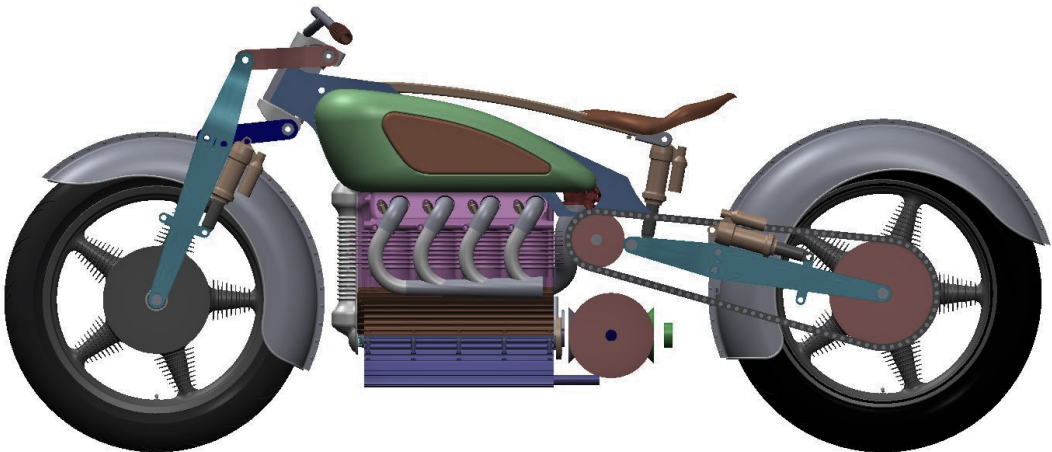

2023



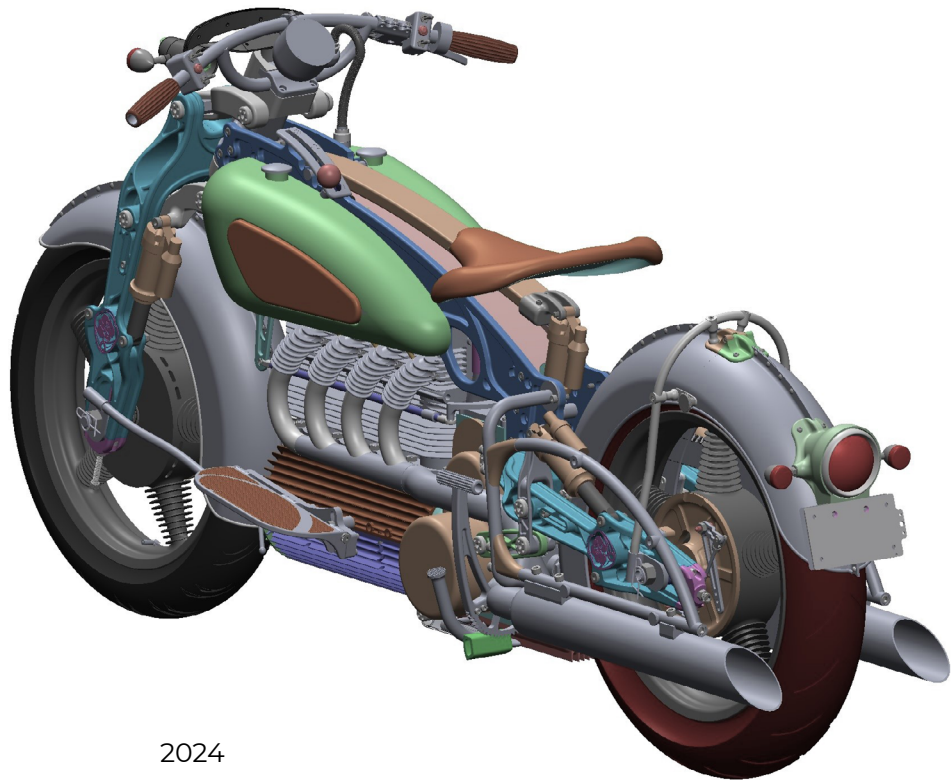

2024

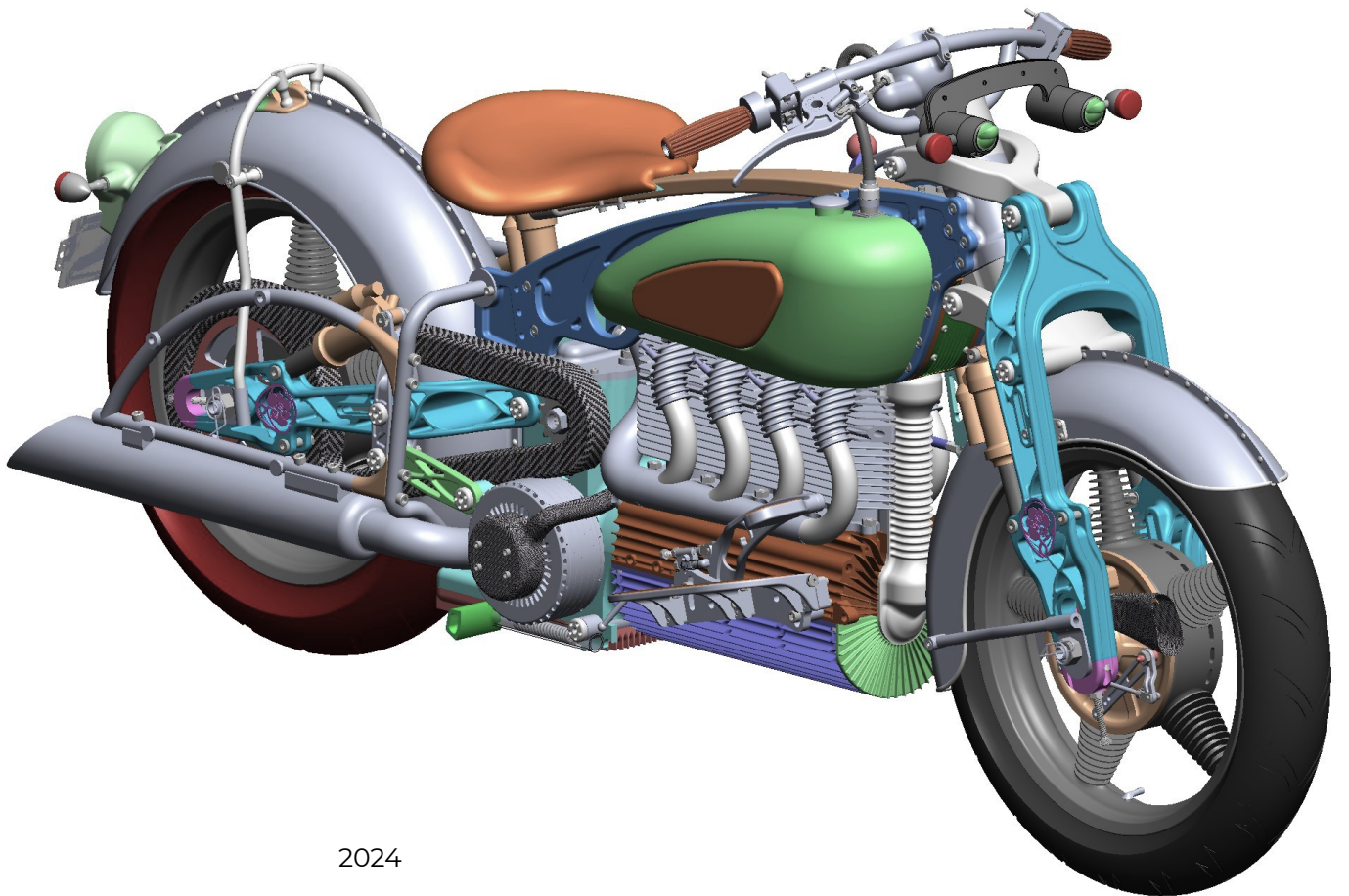

2024

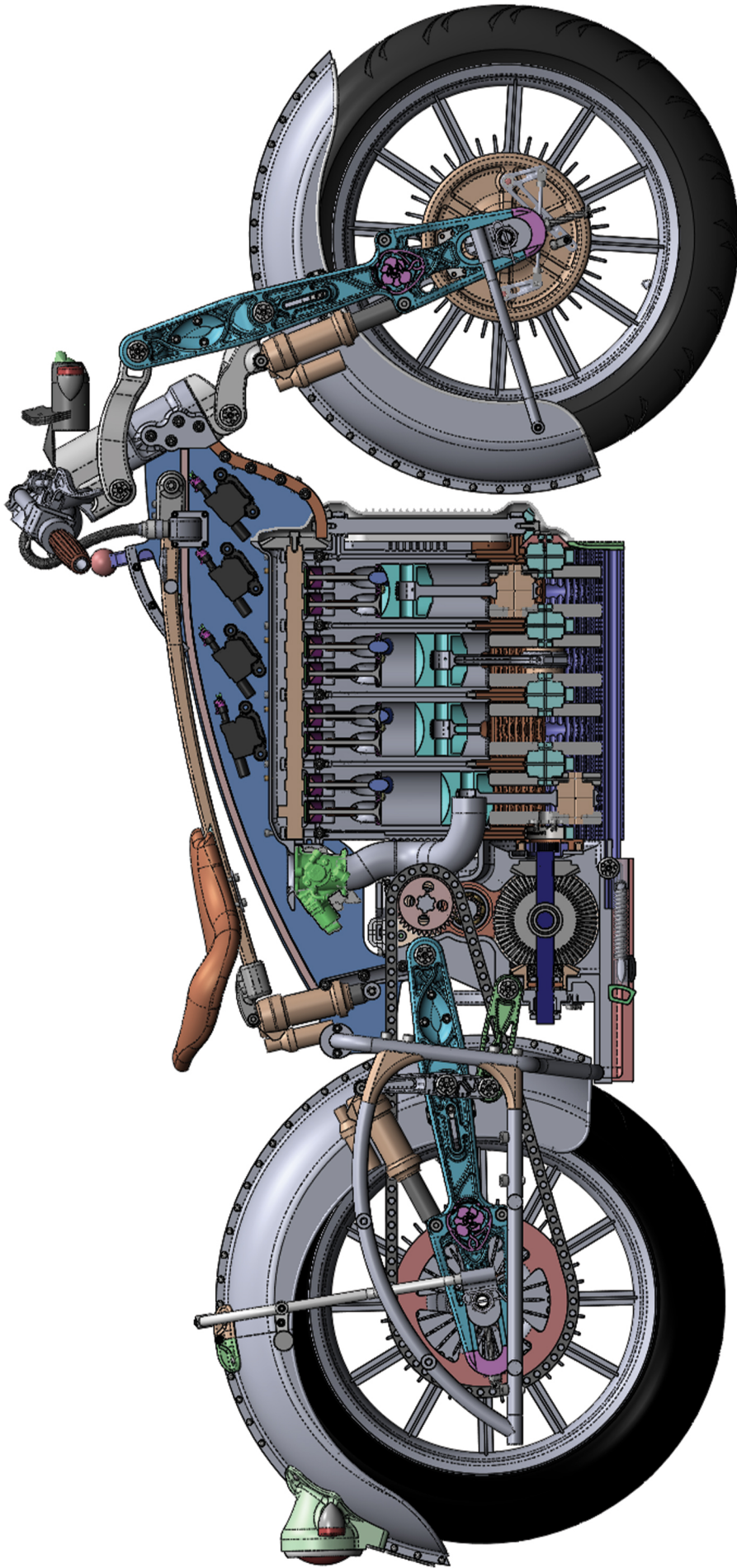







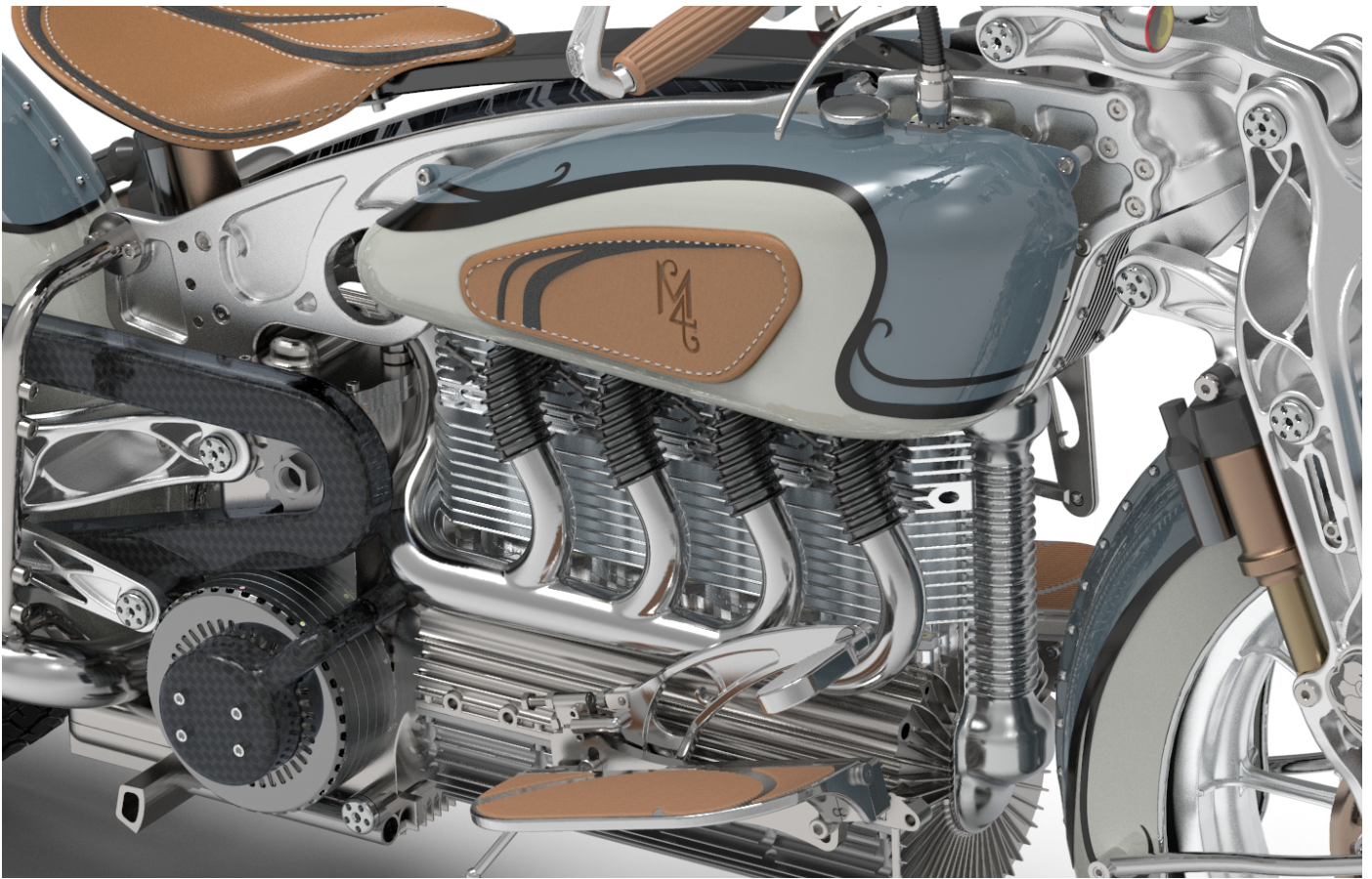

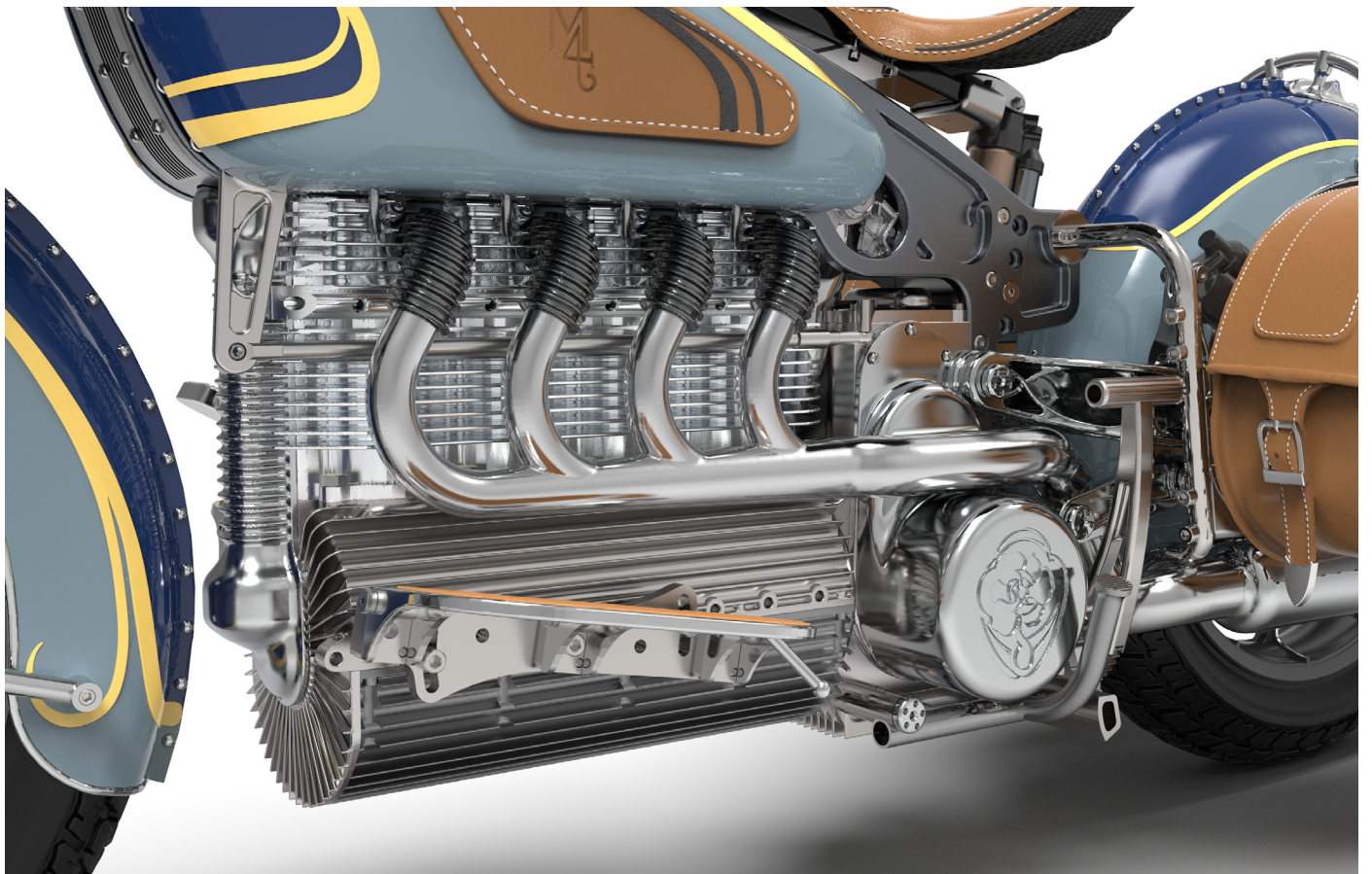
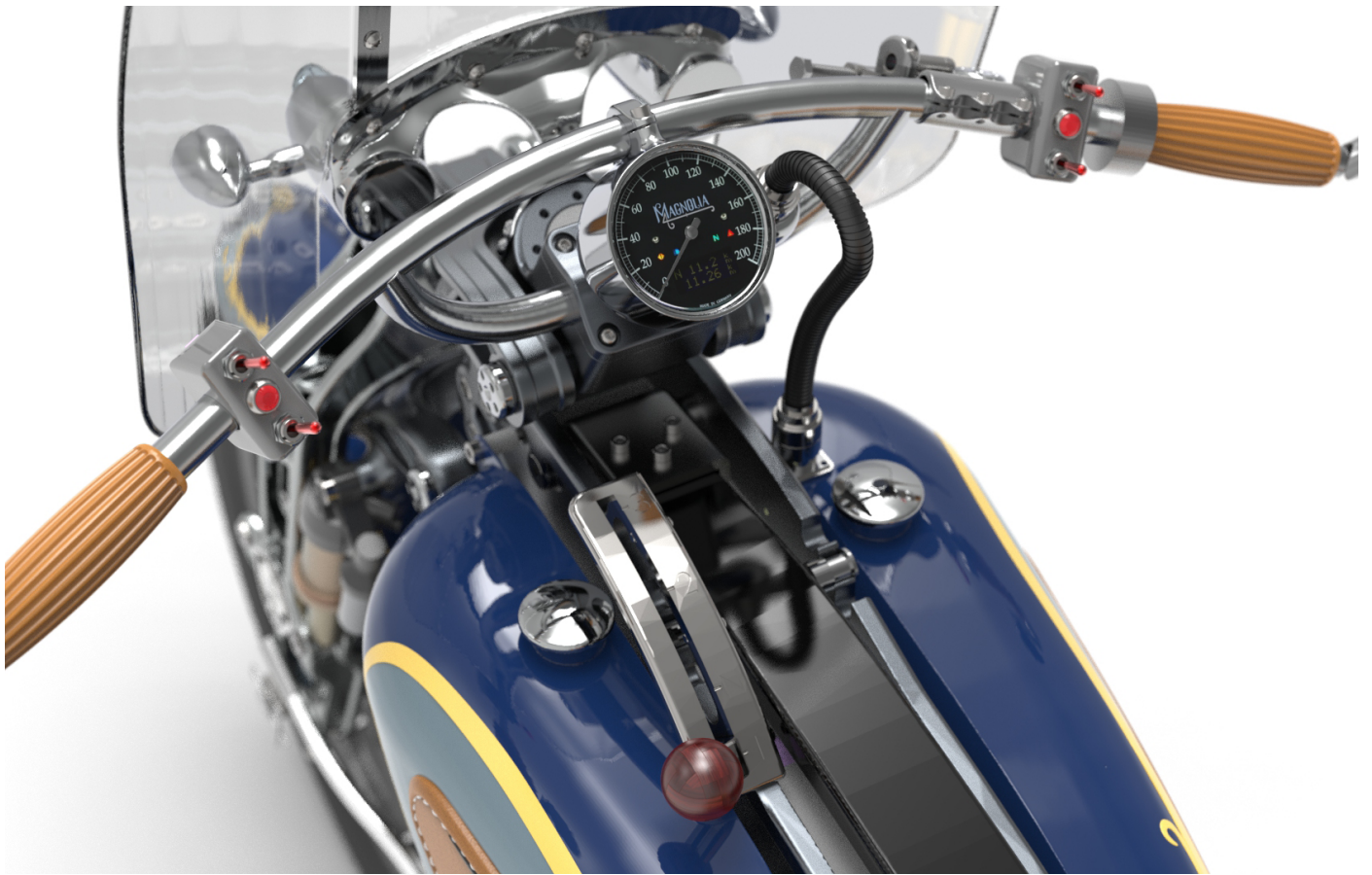

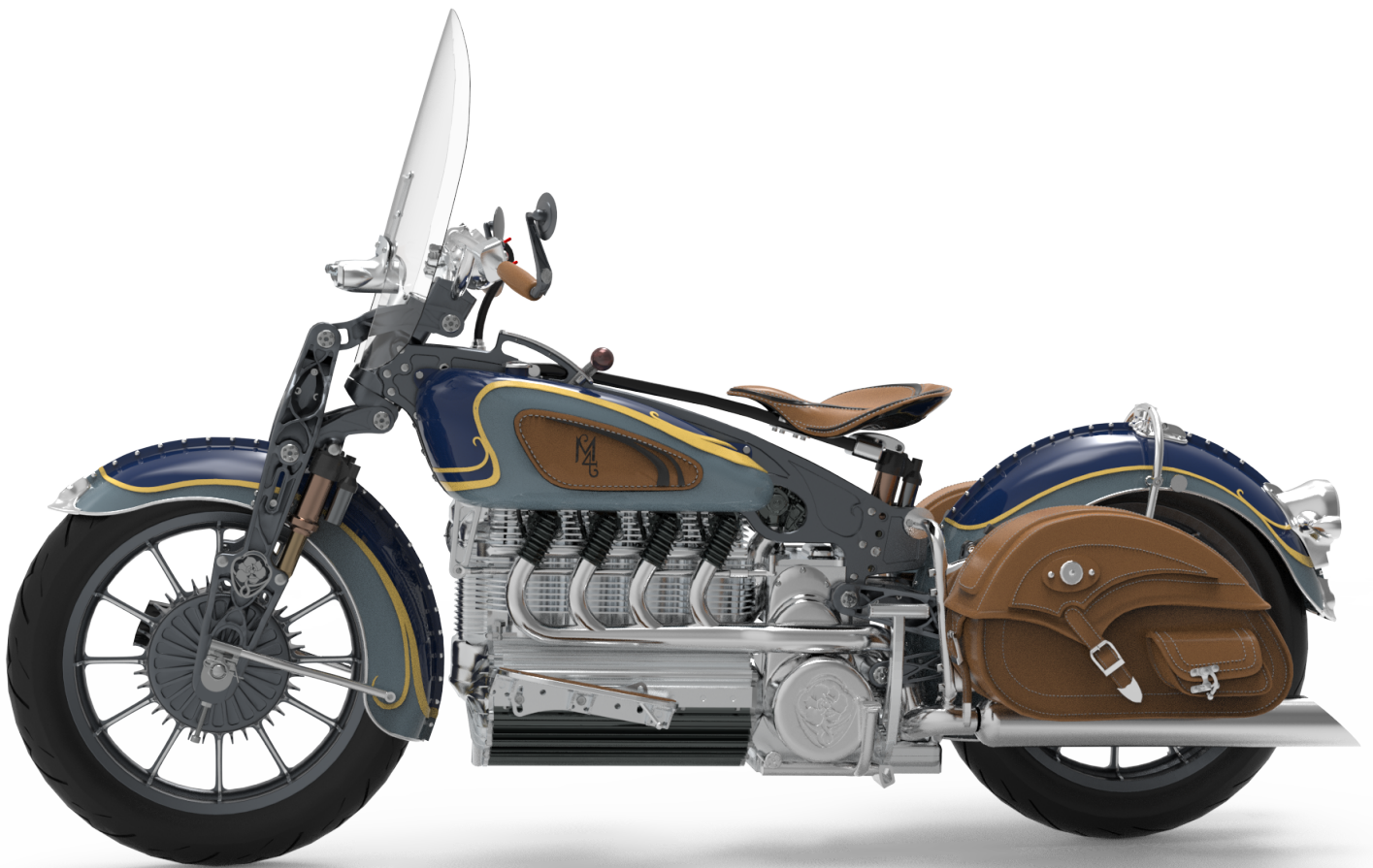



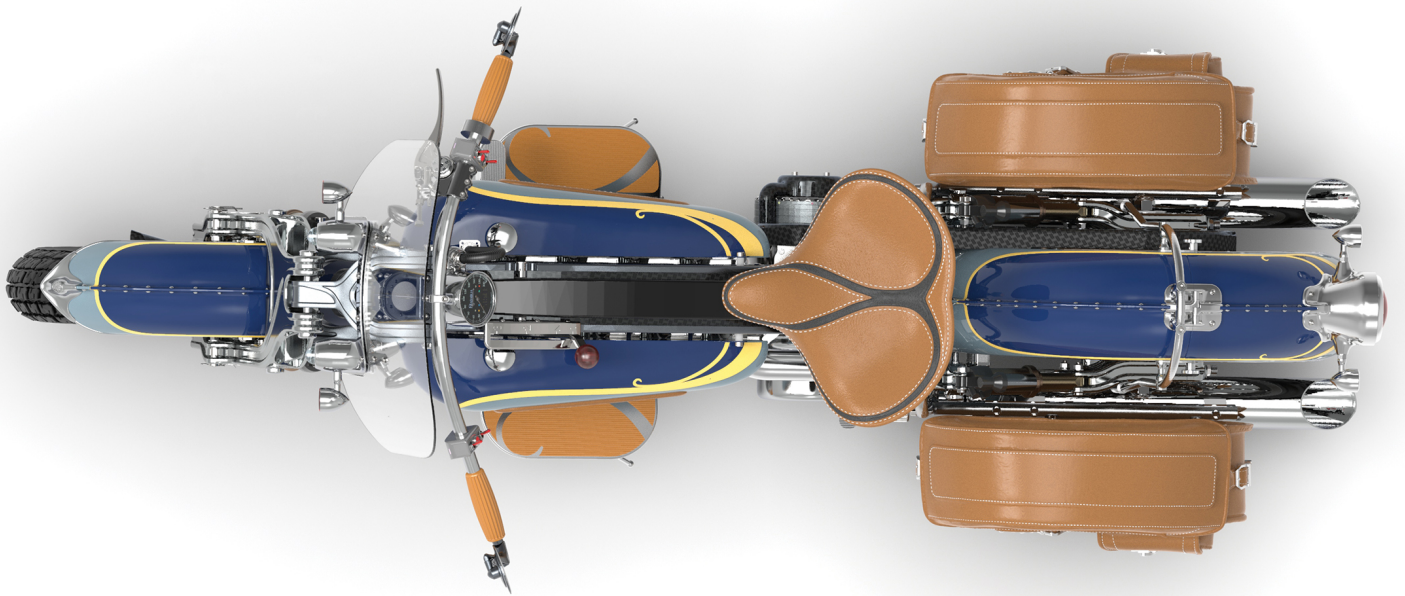



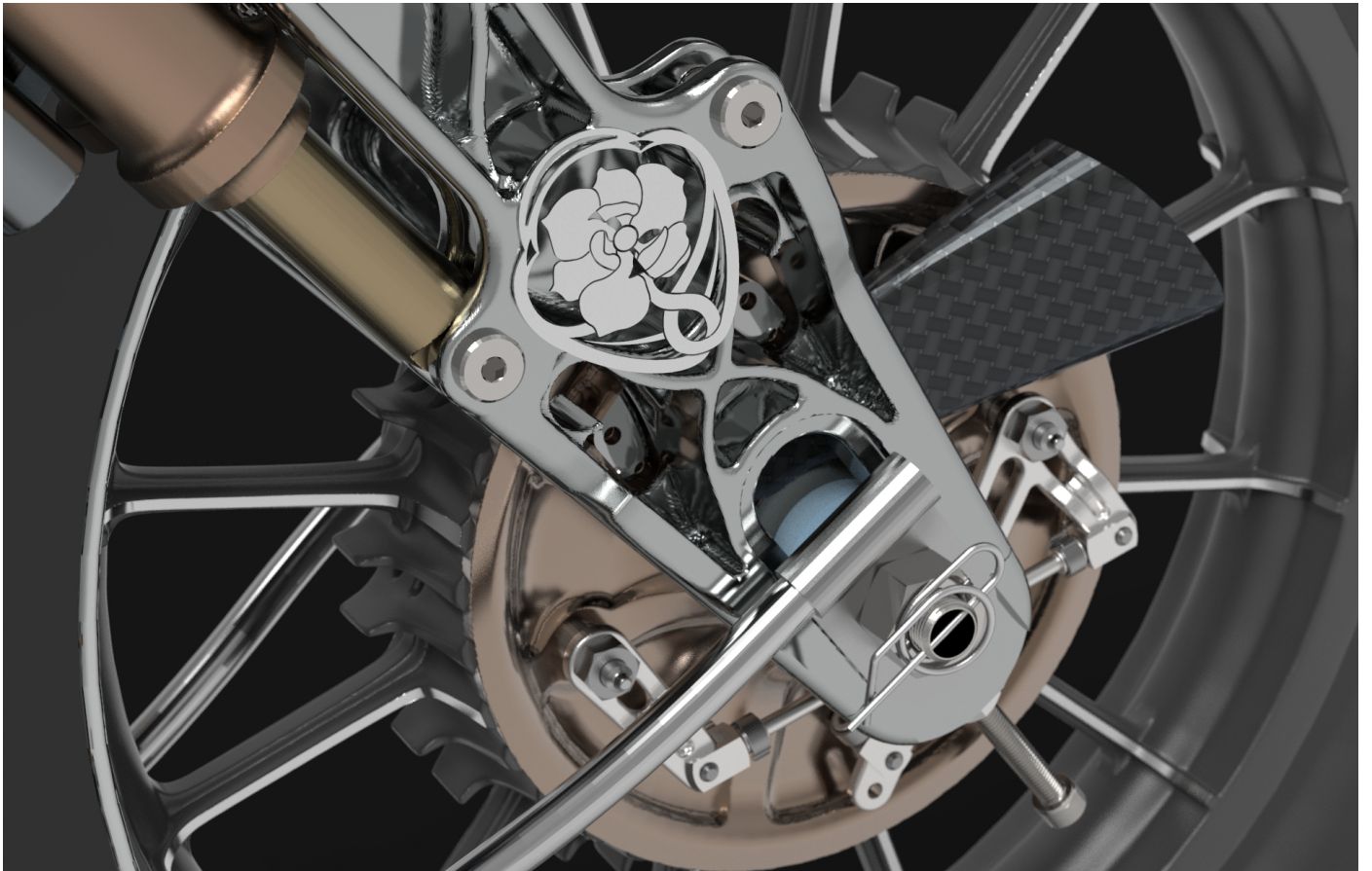



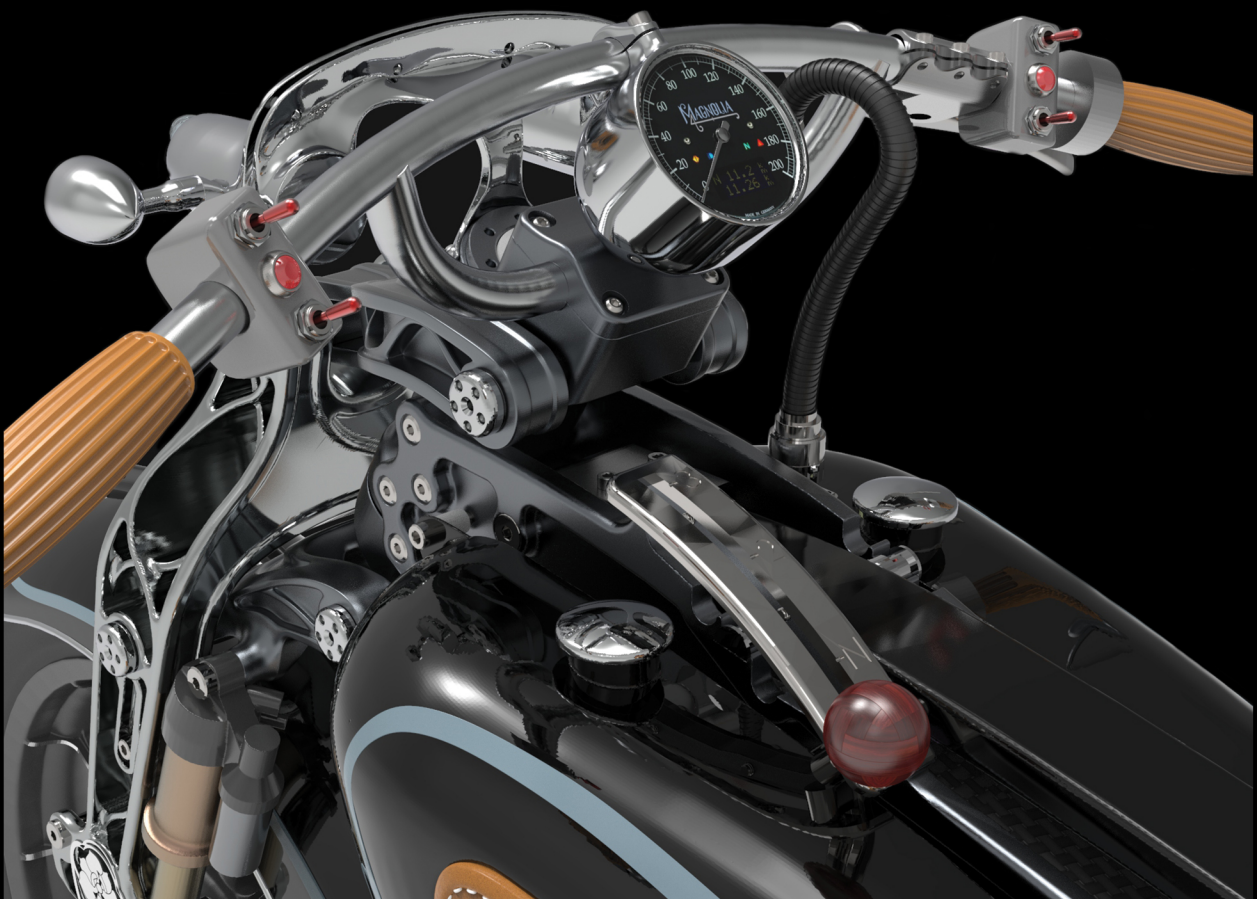









# TEMPUS VERITAS REVELAT

At the intersection of culture and passion lie the icons of design. Only design that originates from within a culture can achieve permanence and endure through multi-generational time scales. By honoring the great engineering legends of motorcycling, automotive, and aviation, then filtering their concepts through our culture, produce a totally unique design language.

Louisiana's Art Nouveau movement, alongside the elegance and decadence infused into our historic city's food and architecture for the past 300 years, shapes and informs our design aesthetic organically. Classic proportion with an immediately recognizable profile as an American motorcycle but with a style that could only come from one place... The oldest Bohemia in the New World - New Orleans - is our inspiration, and from the Latin axiom: "time, truth reveals" our motto for the last great American air-cooled motorcycle.

Understanding that the end of the internal combustion engine is imminent, the mission is clear. Our motorcycle must represent the best of ICE beauty and longevity. The most environmentally friendly vehicle - is the one that never gets thrown away. She will be built to last, an enduring love letter to all things mechanical... but with a completely modular chassis and transmission, can become something else entirely.

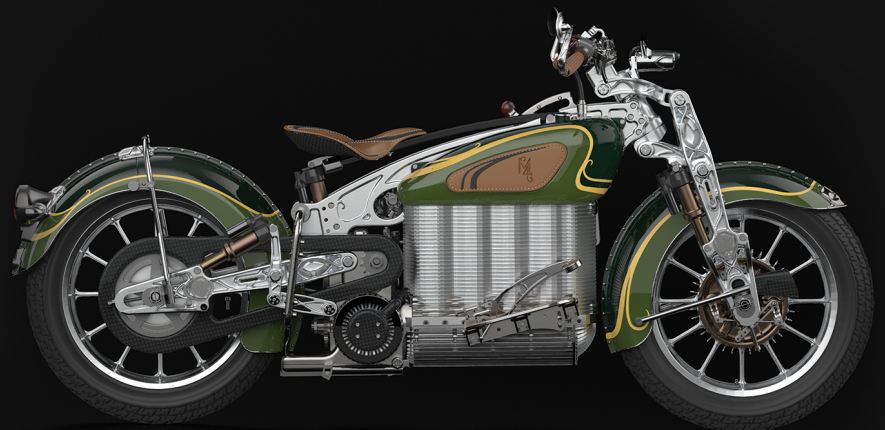

2026 Magnolia 4 E

# NOTES FROM THE TEAM

The visual identity for the Magnolia 4 developed dramatically upon each iteration and feedback session. This iteration and development process included two trips to local museums to directly engage with many of our project inspirations, while also breaking away from the digital to sketch with pencil and paper. A journey that brought me back to my art school days that forced the structured designer perspective to step aside and make way for the artistic roots to shine through.

Working with an artist of the caliber of JT Nesbitt pushed me beyond the conventional, making me and the visual identity for the Magnolia 4 rise to the level of a project built on 25 years of investment. Though not without perseverance, I was challenged to do some of my finest work. I am incredibly proud of the brand identity I have crafted, and I'm excited for the next chapter, watching it all come to life.

- Sara Scioneaux



Florence Creative Marketing  
Owner, Principal Designer

When JT initially sought out services for precise 3D-scanned components, little did we anticipate the unfolding design adventure that lay ahead. Guided by JT's expertise, we synergized efforts to craft a comprehensive visualization of this labor of love. Immerse yourself in the authentic essence of New Orleans culture with this in-line 4-cylinder beauty. The vibrant color palette reminiscent of the Newcomb pottery era echoes a by-gone era and the nostalgia of the last great American Motorcycle era.

- Mark Dowey



3D Scan New Orleans  
Owner & Operator

Moving from Detroit to New Orleans to be a part of this project has been one of the most amazing adventures I have ever embarked upon. What I have found is a city like no other. A wild mixture of beauty, pain, celebration, art, danger, history, and abundant creativity on every corner.

I came here to design an engine for a motorcycle. This endeavor has evolved into designing something much more, a vision that could only come from the mind of JT Nesbitt. Our days are filled with hard work, good music, laughs, and personal growth. What an amazing education in motorcycle design and true passion.

- Jeffrey Sperry



S2 Design Solutions  
Owner & Operator

As the reader will note, the earliest of the sketches date from the first year that I was employed by Matt Chambers as a motorcycle designer. Mr. Chambers was the first person to ever ask me the question of “what would you design, if you could build any motorcycle?”. The monumental implications of that simple question have shaped the trajectory of my life.

The experience of designing and prototyping various motorcycle platforms, all the while running the 4-cylinder sub-routine in the background of my consciousness, have gradually brought the overall concept into sharp focus.

It has taken 24 years of careful consideration, personal growth, and experimentation to truly be ready for the joyful task of bringing this new motorcycle into the world.

Thank you Matt, for asking an awkward and lost young man, such a profound question.

- JT Nesbitt  
9/5/23



# THE NEW ORLEANS MOTORCYCLES



1935 - 1962 Simplex ServiCycle



2003 Confederate G2 Hellcat



2005 Confederate Wraith



2015 Bienville Legacy



2022 Curtiss One

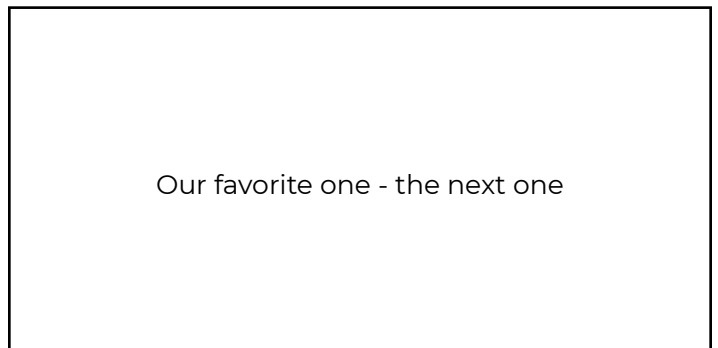

2024 Magnolia 4

